



**DP 4000 Series
Portable Radio
Basic Service Manual**

Foreword

This manual covers all models of the DP series Portable Radios, unless otherwise specified. It includes all the information necessary to maintain peak product performance and maximum working time, using levels 1 and 2 maintenance procedures. This level of service goes down to the board replacement level and is typical of some local service centers, self-maintained customers, and distributors.

Product Safety and RF Exposure Compliance

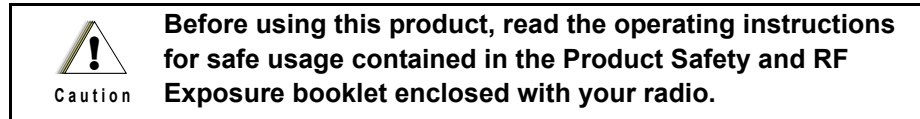

ATTENTION!

This radio is restricted to occupational use only to satisfy FCC RF/ICNIRP energy exposure requirements. Before using this product, read the RF energy awareness information and operating instructions in the Product Safety and RF Exposure booklet enclosed with your radio (Motorola Publication part number 6864117B25) to ensure compliance with RF energy exposure limits.

For a list of Motorola-approved antennas, batteries, and other accessories, visit the following web site: <http://www.motorolasolutions.com/governmentandenterprise>

Computer Software Copyrights

The Motorola products described in this manual may include copyrighted Motorola computer programs stored in semiconductor memories or other media. Laws in the United States and other countries preserve for Motorola certain exclusive rights for copyrighted computer programs, including, but not limited to, the exclusive right to copy or reproduce in any form the copyrighted computer program. Accordingly, any copyrighted Motorola computer programs contained in the Motorola products described in this manual may not be copied, reproduced, modified, reverse-engineered, or distributed in any manner without the express written permission of Motorola. Furthermore, the purchase of Motorola products shall not be deemed to grant either directly or by implication, estoppel, or otherwise, any license under the copyrights, patents or patent applications of Motorola, except for the normal non-exclusive license to use that arises by operation of law in the sale of a product.

Document Copyrights

No duplication or distribution of this document or any portion thereof shall take place without the express written permission of Motorola. No part of this manual may be reproduced, distributed, or transmitted in any form or by any means, electronic or mechanical, for any purpose without the express written permission of Motorola.

Disclaimer

The information in this document is carefully examined, and is believed to be entirely reliable. However, no responsibility is assumed for inaccuracies. Furthermore, Motorola reserves the right to make changes to any products herein to improve readability, function, or design. Motorola does not assume any liability arising out of the applications or use of any product or circuit described herein; nor does it cover any license under its patent rights nor the rights of others.

Trademarks

MOTOROLA, MOTO, MOTOROLA SOLUTIONS and the Stylized M logo are trademarks or registered trademarks of Motorola Trademark Holdings, LLC and are used under license. All other trademarks are the property of their respective owners.

© 2012 Motorola Solutions, Inc.

All rights reserved.

Notes

Document History

The following major changes have been implemented in this manual since the previous edition:

Edition	Description	Date
68012003070-A	Initial Release	Aug. 2011

Notes

Table of Contents

Foreword	iii
Product Safety and RF Exposure Compliance	iii
Computer Software Copyrights	iii
Document Copyrights	iii
Disclaimer.....	iii
Trademarks	iii
 Document History	 v
 Chapter 1 Introduction	 1-1
1.1 Notations Used in This Manual.....	1-1
1.2 Radio Description	1-1
1.2.1 Full Keypad Model.....	1-2
1.2.2 Limited Keypad Model.....	1-3
1.2.3 Non Keypad Model.....	1-4
1.3 .Portable Radio Model Numbering Scheme	1-5
1.4 Model Charts	1-6
1.4.1 VHF Model Chart.....	1-6
1.4.2 UHF Model Chart.....	1-7
1.5 Specifications.....	1-8
 Chapter 2 Test Equipment and Service Aids	 2-1
2.1 Recommended Test Equipment	2-1
2.2 Service Aids.....	2-2
2.3 Programming, Testing and Alignment Cable	2-3
 Chapter 3 Transceiver Performance Testing	 3-1
3.1 General	3-1
3.2 Setup	3-1
3.3 Display Model Test Mode	3-3
3.3.1 Entering Display Radio Test Mode	3-3
3.3.2 RF Test Mode.....	3-3
3.3.3 LED Test Mode.....	3-7
3.3.4 Backlight Test Mode.....	3-7
3.3.5 Speaker Tone Test Mode	3-7
3.3.6 Earpiece Tone Test Mode	3-7
3.3.7 Audio Loopback Earpiece Test Mode.....	3-7
3.3.8 Battery Check Test Mode	3-8
3.3.9 Button/Knob/PTT Test Mode	3-8
3.4 Display Model Test Mode	3-9
3.4.1 Monochrome Display Test.....	3-9
3.4.2 Color Display Test	3-9

3.5	Non-Display Model Test Mode.....	3-10
3.5.1	Entering Non-Display Radio Test Mode	3-10
3.5.2	RF Test Mode	3-10
3.5.3	LED Test Mode.....	3-10
3.5.4	Speaker Tone Test Mode	3-10
3.5.5	Earpiece Tone Test Mode	3-11
3.5.6	Audio Loopback Earpiece Test Mode.....	3-11
3.5.7	Battery Check Test Mode	3-11
3.5.8	Button/Knob/PTT Test Mode	3-11
Chapter 4	Radio Programming and Tuning	4-1
4.1	Introduction	4-1
4.2	Customer Programming Software Setup	4-1
4.3	AirTracer Application Tool.....	4-1
4.4	Radio Tuning Setup	4-2
Chapter 5	Disassembly/Reassembly Procedures	5-1
5.1	Introduction	5-1
5.2	Preventive Maintenance	5-1
5.2.1	Inspection	5-1
5.2.2	Cleaning Procedures	5-1
5.3	Safe Handling of CMOS and LDMOS Devices	5-2
5.4	Repair Procedures and Techniques – General.....	5-4
5.5	Disassembling and Reassembling the Radio — General	5-5
5.6	Radio Disassembly – Detailed	5-6
5.6.1	Front Cover from Chassis Disassembly	5-6
5.6.2	Chassis Disassembly.....	5-10
5.6.3	Keypad, Display, and Keypad Board Disassembly.....	5-12
5.6.4	Speaker, Microphone, and Universal Connector Flex Disassembly.....	5-14
5.6.5	Emergency Button Assembly Dissassembly	5-17
5.7	Radio Reassembly - Detailed	5-19
5.7.1	Emergency Button and Speaker Reassembly	5-19
5.7.2	Keypad, Display and Keypad Board Reassembly	5-22
5.7.3	Chassis Reassembly	5-23
5.7.4	Chassis and Front Cover Reassembly	5-27
5.7.5	Bluetooth Antenna Kit Disassembly/Reassembly.....	5-28
5.7.5.1	Bluetooth Antenna Kit Disassembly.....	5-28
5.7.5.2	Bluetooth Antenna Kit Reassembly	5-29
5.7.6	GOB Installation.....	5-30
5.8	Ensuring Radio Immersibility	5-32
5.8.1	Servicing	5-32
5.8.2	Accidental Immersion	5-32
5.8.3	Specialized Test Equipment	5-32
5.8.4	Vacuum Pump Kit NLN9839.....	5-32
5.8.5	Pressure Pump Kit NTN4265	5-33
5.8.6	Miscellaneous Hardware	5-33
5.8.7	Vacuum Test.....	5-33
5.8.8	Pressure Test	5-34
5.8.9	Troubleshooting Leak Areas.....	5-35
5.8.9.1	Front Housing	5-35

	5.8.9.2	Chassis (Main Seal O-ring)	5-35
	5.8.9.3	Battery Contact Seal.....	5-36
	5.8.9.4	Breathing Vent Membrane and Breathing Vent Label	5-37
	5.8.9.5	Battery Maintenance.....	5-37
	5.8.10	Troubleshooting Charts	5-38
5.9		Radio Exploded Mechanical Views and Parts Lists	5-41
	5.9.1	Full Keypad Model Exploded View and Parts List	5-41
	5.9.2	Limited Keypad Model Exploded View and Parts List	5-44
	5.9.3	Non Keypad Model Exploded View and Parts List	5-47
	5.9.4	Torque Chart	5-51

Chapter 6 Basic Troubleshooting 6-1

6.1	Introduction	6-1
6.2	Replacement Back Cover Kit Procedures	6-1
6.3	Power-Up Error Codes (Display Model only).....	6-2
6.4	Operational Error Codes	6-4

Appendix A EMEA Regional Warranty, Service and Technical Support .. A-1

A.1	Warranty and Service Support.....	A-1
	A.1.1 Warranty Period and Return Instructions	A-1
	A.1.2 After Warranty Period	A-1
A.2	European Radio Support Centre (ERSC)	A-2
A.3	Piece Parts	A-2
A.4	Technical Support.....	A-3
A.5	Further Assistance From Motorola	A-3

Appendix B Limited Level 3 Servicing B-1

B.1	Maintenance	B-1
B.2	Chip Components	B-1
B.3	Component and Parts list	B-2

Glossary Glossary-1

List of Figures

Figure 1-1.	Full Keypad Model.....	1-2
Figure 1-2.	Limited Keypad Model.....	1-3
Figure 1-3.	Non Keypad Model.....	1-4
Figure 1-4.	Portable Radio Model Numbering Scheme	1-5
Figure 2-1.	Programming, Testing and Alignment Cable	2-3
Figure 2-2.	Pin Layout of Side Connector	2-4
Figure 3-1.	Battery Check Test Mode Display	3-8
Figure 4-1.	CPS Programming Setup.....	4-1
Figure 4-2.	Radio Tuning Equipment Setup	4-2
Figure 5-1.	Antenna and Battery removal.....	5-6
Figure 5-2.	Channel Selector and Volume Knob removal.	5-7
Figure 5-3.	Shroud removal.....	5-8
Figure 5-4.	Chassis removal.....	5-8
Figure 5-5.	Disconnecting the chassis.....	5-9
Figure 5-6.	Chassis disassembly.....	5-10
Figure 5-7.	O-ring removal	5-11
Figure 5-8.	Keypad, Display, and Keypad Board disassembly for Full Keypad	5-12
Figure 5-9.	Keypad, Display, and Keypad Board Disassembly for Limited Keypad.....	5-13
Figure 5-10.	Speaker removal for Full Keypad	5-14
Figure 5-11.	Speaker removal for Limited Keypad	5-15
Figure 5-12.	Speaker removal for Non-Keypad	5-16
Figure 5-13.	Emergency Button disassembly for Full Keypad Model	5-17
Figure 5-14.	Emergency Button disassembly for Non Keypad Model	5-18
Figure 5-15.	Emergency Button reassembly for Full Keypad	5-19
Figure 5-16.	Emergency Button reassembly for Non Keypad	5-20
Figure 5-17.	Speaker reassembly for Full Keypad.....	5-20
Figure 5-18.	Speaker reassembly for Non Keypad.....	5-21
Figure 5-19.	Keypad, Display, and Keypad Board reassembly for Full Keypad	5-22
Figure 5-20.	O-ring reassembly.	5-23
Figure 5-21.	Chassis reassembly	5-24
Figure 5-22.	GOB reassembly	5-25
Figure 5-23.	O-ring reassembly	5-26
Figure 5-24.	Chassis reassembly	5-27
Figure 5-25.	Bluetooth removal for Full Keypad	5-28
Figure 5-26.	Bluetooth removal for Non Keypad	5-28
Figure 5-27.	Bluetooth reassembly for Full Keypad.....	5-29
Figure 5-28.	Bluetooth reassembly for Non Keypad.....	5-29
Figure 5-29.	Connector Fitting - Fitting Seal Pump Connector.....	5-32
Figure 5-30.	Full Keypad Model Exploded View	5-41
Figure B-1.	PCB Top View	B-2
Figure B-2.	PCB Bottom View.....	B-2

List of Tables

Table 1-1.	Radio Frequency Ranges and Power Levels.....	1-1
Table 2-1.	Recommended Test Equipment.....	2-1
Table 2-2.	Service Aids.....	2-2
Table 2-3.	Pin Configuration of Side Connector.....	2-4
Table 3-1.	Initial Equipment Control Settings.....	3-1
Table 3-2.	Front Panel Access Test Mode Displays.....	3-3
Table 3-3.	Test Environments.....	3-4
Table 3-4.	Test Frequencies.....	3-4
Table 3-5.	Transmitter Performance Checks.....	3-5
Table 3-6.	Receiver Performance Checks.....	3-6
Table 4-1.	Software Installation Kits Radio Tuning Setup.....	4-1
Table 5-1.	Lead Free Solder Wire Part Number List.....	5-4
Table 5-2.	Lead Free Solder Paste Part Number List.....	5-4
Table 5-3.	Full Keypad Model Exploded View Parts List.....	5-42
Table 5-4.	Limited Keypad Model Exploded View Parts List.....	5-45
Table 5-5.	Non-Display Model Exploded View Parts List.....	5-48
Table 5-6.	Additional Part List information.....	5-49
Table 5-7.	Torque Specifications for Screws.....	5-51
Table 6-1.	Power-Up Error Codes.....	6-2
Table 6-2.	Operational Error Codes.....	6-4

Related Publications

IMPRES Adaptive Single-Unit Charger User Manual	6816787H01
IMPRES Adaptive Multi-Unit Charger User Manual.....	6816789H01
IMPRES Adaptive Multi-Unit Charger Service Manual	6871357L01
Remote Speaker Microphone User Manual	6871003L01
IMPRES Remote Speaker Microphone User Manual	6871004L01
Factory Mutual Approval Manual	6871532L01
Product Safety and RF Exposure	6864117B25

I

Chapter 1 Introduction

1.1 Notations Used in This Manual

Throughout the text in this publication, you will notice the use of note and caution notations. These notations are used to emphasize that safety hazards exist, and due care must be taken and observed.

NOTE An operational procedure, practice, or condition that is essential to emphasize.

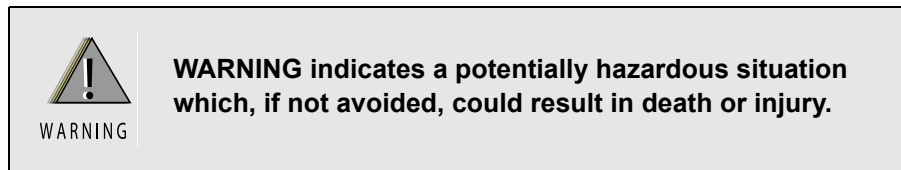
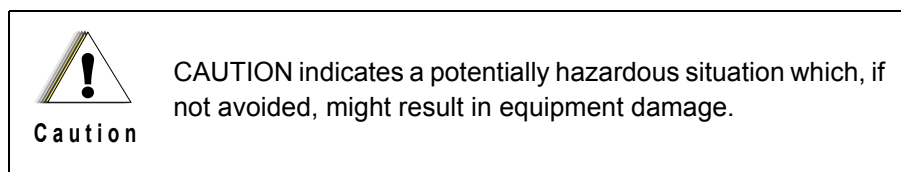

1.2 Radio Description

The DP series portable radios are available in the following frequency ranges and power levels.

Table 1-1. Radio Frequency Ranges and Power Levels

Frequency Band	Bandwidth	Power Level
VHF	136–174 MHz	1 Watt or 5 Watt
UHF	403–527 MHz	1 Watt or 4 Watt

These digital radios are among the most sophisticated two-way radios available. They have a robust design for radio users who need high performance, quality, and reliability in their daily communications. This architecture provides the capability of supporting a multitude of legacy and advanced features resulting in a more cost-effective two-way radio communications solution.

1.2.1 Full Keypad Model

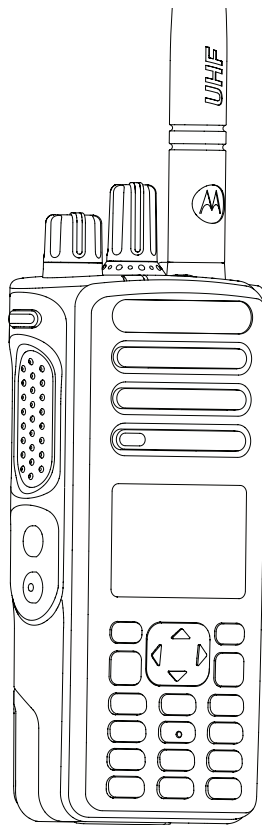

Figure 1-1. Full Keypad Model

- ON/OFF/VOLUME KNOB – Rotate clockwise until click is heard to turn on radio; rotate counter-clockwise until click is heard to turn off radio. Rotate clockwise to increase volume level; rotate counter-clockwise to decrease volume level.
- LED INDICATORS – Red, green and orange light-emitting diodes indicate operating status.
- LCD (Liquid Crystal Display):
 - 132x90 highly transfective color display provides visual information about many radio features.
- MENU NAVIGATION KEYS – Five keys to provide menu navigation and selection interface.
- KEYPAD – Twelve keys that allows the user to input characters for various text based operations. (For color display only)
- FRONT BUTTONS and SIDE BUTTONS – These five buttons are field programmable using the CPS.
- CHANNEL SELECTOR KNOB – Rotate clockwise to increment and counter clockwise to decrement the channel.
- PUSH-TO-TALK (PTT) – Press to execute voice operations (e.g. Group call and Private Call).
- ANTENNA – Provides the needed RF amplification when transmitting or receiving.
- MICROPHONE – Allows the voice to be sent when PTT or voice operations are activated.
- UNIVERSAL CONNECTOR FOR ACCESSORIES – Interface point for all accessories to be used with the radio. It has twelve points to which specific accessories will connect and be activated.
- EMERGENCY BUTTON – Turns on and off the Emergency Operations.

- SPEAKER – Outputs all tones and audio that are generated by the radio (e.g. features like keypad tones and voice audio).

1.2.2 Limited Keypad Model

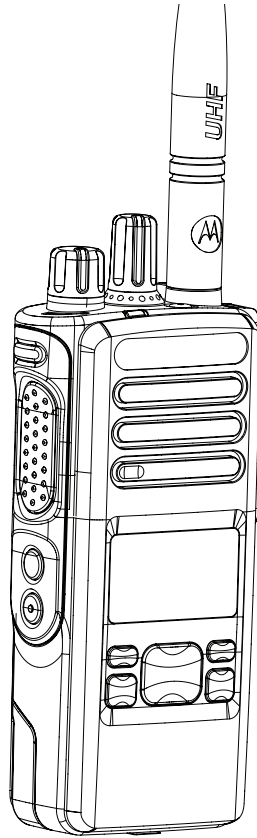

Figure 1-2. Limited Keypad Model

- ON/OFF/VOLUME KNOB – Rotate clockwise until click is heard to turn on radio; rotate counter-clockwise until click is heard to turn off radio. Rotate clockwise to increase volume level; rotate counter-clockwise to decrease volume level.
- LED INDICATORS – Red, green and orange light-emitting diodes indicate operating status.
- SIDE BUTTONS – These 3 buttons are field programmable using the CPS.
- CHANNEL SELECTOR KNOB – Rotate clockwise to increment and counter clockwise to decrement the channel.
- PUSH-TO-TALK (PTT) – Press to execute voice operations (e.g. Group call and Private Call).
- ANTENNA – Provides the needed RF amplification when transmitting or receiving.
- MICROPHONE – Allows the voice to be sent when PTT or voice operations are activated.
- UNIVERSAL CONNECTOR FOR ACCESSORIES – Interface point for all accessories to be used with the radio. It has twelve points to which specific accessories will connect to and be activated.
- EMERGENCY BUTTON – Turns on and off the Emergency Operations.
- SPEAKER – Outputs all tones and audio that are generated by the radio (e.g. features like keypad tones and voice audio)

1.2.3 Non Keypad Model

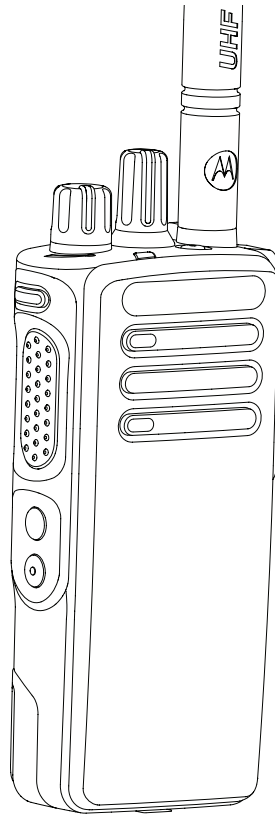

Figure 1-3. Non Keypad Model

- ON/OFF/VOLUME KNOB – Rotate clockwise until click is heard to turn on radio; rotate counter-clockwise until click is heard to turn off radio. Rotate clockwise to increase volume level; rotate counter-clockwise to decrease volume level.
- LED INDICATORS – Red, green and orange light-emitting diodes indicate operating status.
- SIDE BUTTONS – These 3 buttons are field programmable using the CPS.
- CHANNEL SELECTOR KNOB – Rotate clockwise to increment and counter clockwise to decrement the channel.
- PUSH-TO-TALK (PTT) – Press to execute voice operations (e.g. Group call and Private Call).
- ANTENNA – Provides the needed RF amplification when transmitting or receiving.
- MICROPHONE – Allows the voice to be sent when PTT or voice operations are activated.
- UNIVERSAL CONNECTOR FOR ACCESSORIES – Interface point for all accessories to be used with the radio. It has twelve points to which specific accessories will connect to and be activated.
- EMERGENCY BUTTON – Turns on and off the Emergency Operations.
- SPEAKER – Outputs all tones and audio that are generated by the radio (e.g. features like keypad tones and voice audio)

1.3 .Portable Radio Model Numbering Scheme

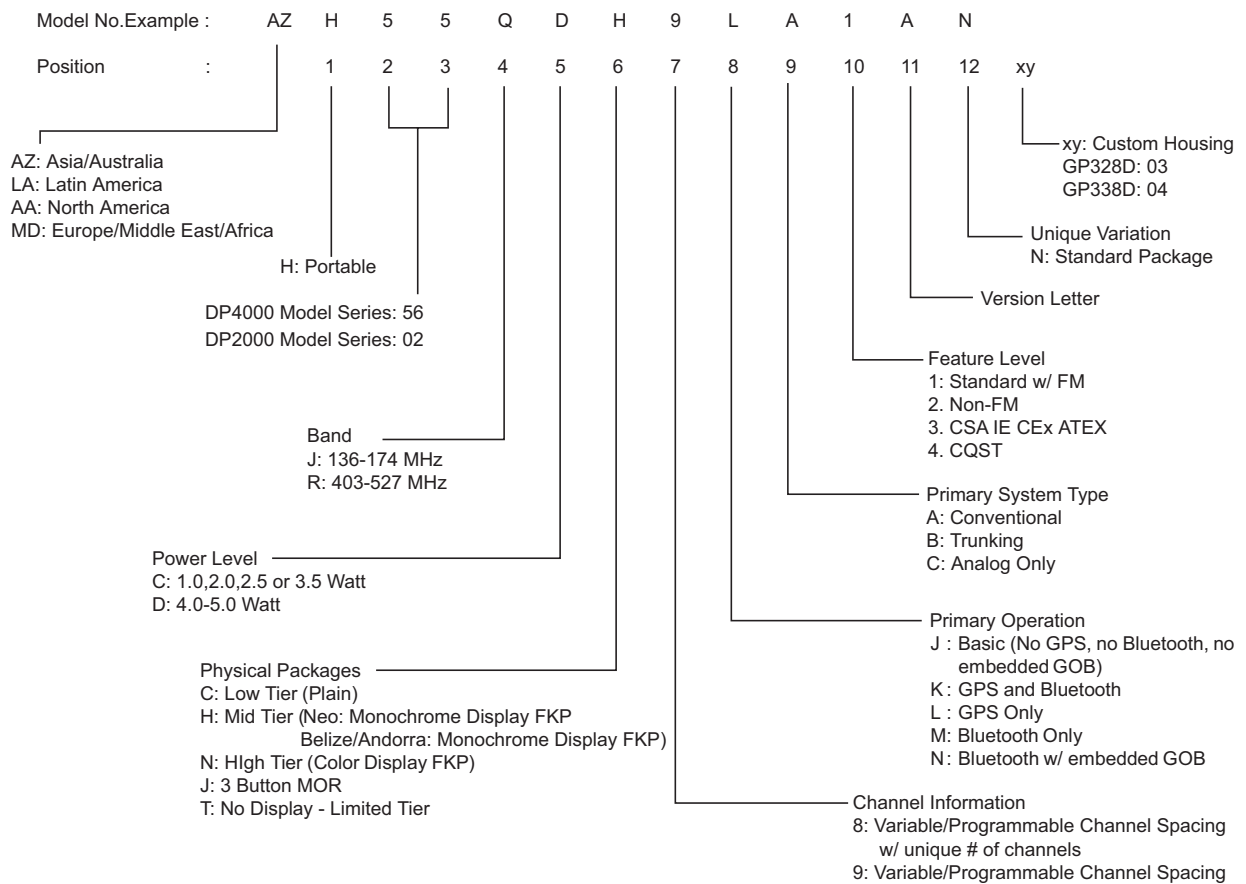

Figure 1-4. Portable Radio Model Numbering Scheme

1.4 Model Charts

1.4.1 VHF Model Chart

DP4000 Series, VHF, 136–174 MHz							
Model					Description		
MDH56JDN9KA1AN					136–174, 5W, MOTOTRBO Full Keypad Portable with GPS		
MDH56JDN9JA1AN					136–174, 5W, MOTOTRBO Full Keypad Portable		
MDH56JDH9KA1AN					136–174, 5W, MOTOTRBO Limited Keypad Portable with GPS		
MDH56JDH9JA1AN					136–174, 5W, MOTOTRBO Limited Keypad Portable		
MDH56JDC9KA1AN					136–174, 5W, MOTOTRBO Non Keypad Portable with GPS		
MDH56JDC9JA1AN					136–174, 5W, MOTOTRBO Non Keypad Portable		
					Item	Description	
X					PMLD4480_S	BC Kit, 136–174, 5W, MOTOTRBO Full Keypad Portable with GPS	
	X				PMLD4481_S	BC Kit, 136–174, 5W, MOTOTRBO Full Keypad Portable	
		X			PMLD4483_S	BC Kit, 136–174, 5W, MOTOTRBO Limited Keypad Portable with GPS	
			X		PMLD4484_S	BC Kit, 136–174, 5W, MOTOTRBO Limited Keypad Portable	
				X	PMLD4486_S	BC Kit, 136–174, 5W, MOTOTRBO Non Keypad Portable with GPS	
				X	PMLD4487_S	BC Kit, 136–174, 5W, MOTOTRBO Non Keypad Portable	
X					PMLN6116_	Front Cover Kit, Full Keypad Portable with Bluetooth (English)	
X					PMLN6113_	Front Cover Kit, Full Keypad Portable with Bluetooth (Cyrillic)	
X					PMLN6114_	Front Cover Kit, Full Keypad Portable with Bluetooth (Arabic)	
	X				PMLN5961_	Front Cover Kit, Full Keypad Portable (English)	
	X				PMLN5689_	Front Cover Kit, Full Keypad Portable (Cyrillic)	
	X				PMLN5963_	Front Cover Kit, Full Keypad Portable (Arabic)	
		X			PMLN6112_	Front Cover Kit, Limited Keypad Portable with Bluetooth	
			X		PMLN5690_	Front Cover Kit, Limited Keypad Portable	
				X	PMLN6111_	Front Cover Kit, Non Keypad Portable with Bluetooth	
				X	PMLN5691_	Front Cover Kit, Non Keypad Portable	
X	X	X	X	X	X	PMLN5718_S	Option Board Kit
X	X	X	X	X	X	PMAD4117_	VHF Helical antenna (136–155 MHz)
X	X	X	X	X	X	PMAD4116_	VHF Helical antenna (144–165 MHz)
X	X	X	X	X	X	PMAD4118_	VHF Helical antenna (152–174 MHz)
X	X	X	X	X	X	PMAD4119_	VHF stubby antenna (136–148 MHz)
X	X	X	X	X	X	PMAD4120_	VHF stubby antenna (146–160 MHz)
X	X	X	X	X	X	PMAD4121_	VHF stubby antenna (160–174 MHz)

1.4.2 UHF Model Chart

DP4000 Series, UHF, 403–527 MHz						
Model				Description		
MDH56RDN9KA1AN				403–527 MHz, 4W, MOTOTRBO Full Keypad Portable with GPS		
MDH56RDN9JA1AN				403–527 MHz, 4W, MOTOTRBO Full Keypad Portable		
MDH56RDH9KA1AN				403–527 MHz, 4W, MOTOTRBO Limited Keypad Portable with GPS		
MDH56RDH9JA1AN				403–527 MHz, 4W, MOTOTRBO Limited Keypad Portable		
MDH56RDC9KA1AN				403–527 MHz, 4W, MOTOTRBO Non Keypad Portable with GPS		
MDH56RDC9JA1AN				403–527 MHz, 4W, MOTOTRBO Non Keypad Portable		
				Item	Description	
X				PMLE4689_S	BC Kit, 403–527 MHz, 4W, MOTOTRBO Full Keypad Portable with GPS	
	X			PMLE4690_S	BC Kit, 403–527 MHz, 4W, MOTOTRBO Full Keypad Portable	
		X		PMLE4692_S	BC Kit, 403–527 MHz, 4W, MOTOTRBO Limited Keypad Portable with GPS	
			X	PMLE4693_S	BC Kit, 403–527 MHz, 4W, MOTOTRBO Limited Keypad Portable	
				X	PMLE4695_S	BC Kit, 403–527 MHz, 4W, MOTOTRBO Non Keypad Portable with GPS
				X	PMLE4696_S	BC Kit, 403–527 MHz, 4W, MOTOTRBO Non Keypad Portable
					PMLN6116_	Front Cover Kit, Full Keypad Portable with Bluetooth (English)
					PMLN6113_	Front Cover Kit, Full Keypad Portable with Bluetooth (Cyrillic)
					PMLN6114_	Front Cover Kit, Full Keypad Portable with Bluetooth (Arabic)
					PMLN5961_	Front Cover Kit, Full Keypad Portable (English)
					PMLN5689_	Front Cover Kit, Full Keypad Portable (Cyrillic)
					PMLN5963_	Front Cover Kit, Full Keypad Portable (Arabic)
					PMLN6112_	Front Cover Kit, Limited Keypad Portable with Bluetooth
					PMLN5690_	Front Cover Kit, Limited Keypad Portable
					PMLN6111_	Front Cover Kit, Non Keypad Portable with Bluetooth
					PMLN5691_	Front Cover Kit, Non Keypad Portable
					PMLN5718_S	Option Board Kit
					PMAE4068_	UHF Whip Antenna 403–527 MHz
					PMAE4069_	UHF Stubby Antenna 403–450 MHz
					PMAE4070_	UHF Stubby Antenna 440–490 MHz
					PMAE4071_	UHF Stubby Antenna 470–527 MHz
					PMAE4079_	UHF Slim Whip Antenna 403–527 MHz

1.5 Specifications

General	Full Keypad DP4801/DP4800	Limited Keypad DP4601/DP4600	Non Keypad DP4401/DP4400
Channel Capacity	1000	1000	32
Frequency	VHF: 136 – 174 MHz UHF: 403 – 527 MHz		
Dimensions (HxWxT) w/ NiMH battery	130.3 x 55.2 x 38.7 mm		130.3 x 55.15 x 37.2 mm
Weight (with NiMH battery) (with Lilon FM battery) (with Lilon non-FM battery)	425.5g 365.5g 355.5g	426.5 366.5 356.5	393g 333g 323g
Power Supply	7.5V nominal		
FCC Description	UHF: ABZ99FT4086 VHF: ABZ99FT3085		
IC Description	UHF: 109AB-99FT4086 VHF: 109AB-99FT3085		
Average battery life at 5/5/90 duty cycle with battery saver enabled in carrier squelch and transmitter in high power.			
Core NiMH (1300mAh) battery	Analog: 6.7 hrs Digital: 9.8 hrs	Analog: 7 hrs Digital: 10.2 hrs	Analog: 7 hrs Digital: 10.2 hrs
IMPRES Li-ion Slim (1500mAH) battery	Analog: 7.7 hrs Digital: 11.3 hrs	Analog: 8 hrs Digital: 11.8 hrs	Analog: 8 hrs Digital: 11.8 hrs
IMPRES Hi-Cap Li-ion Non-FM (2150 mAH) battery	Analog: 11.1 hrs Digital: 16.2 hrs	Analog: 11.5 hrs Digital: 17 hrs	Analog: 11.5 hrs Digital: 17 hrs
IMPRES Hi-Cap Li-ion FM (2300 mAH) battery	Analog: 11.9 hrs Digital: 17.3 hrs	Analog: 12.3 hrs Digital: 18.1 hrs	Analog: 12.3 hrs Digital: 18.1 hrs

NOTE Weight can have 5% margin of error

Factory Mutual Approval

MOTOTRBO DP4000 Series portable radios have been certified by FM in accordance with U.S. Codes as intrinsically safe for use in Class I, II, III, Division 1, Groups C, D, E, F, G, when properly equipped with a Motorola FM approved battery option. They are also approved for use in Class I, Division 2, Groups A, B, C, D.

Receiver	Full Keypad DP4801/DP4800	Limited Keypad DP4601/DP4600	Non Keypad DP4401/DP4400
Frequencies	VHF: 136 – 174MHz UHF: 403 – 527MHz		
Channel Spacing	12.5 kHz/ 20 kHz/ 25 kHz		
Frequency Stability (-30°C to +60°C)	+/-0.5 ppm		
Analog Sensitivity (12 dB SINAD) Typical	0.3 μ V		
Digital Sensitivity (5% BER)	0.25 μ V 0.19 μ V (typical)		
Intermodulation (TIA603C)	70 dB		
Adjacent Channel Selectivity TIA603 TIA603C	60 dB @ 12.5 kHz, 70 dB @ 20 kHz/ 25 kHz 45 dB @ 12.5 kHz, 70 dB @ 20 kHz/ 25 kHz		
Spurious Rejection (TIA603C)	70 dB		
Rated Audio	0.5 W		
Audio Distortion @ Rated Audio	5% (typical)		
Hum and Noise	-40 dB @ 12.5 kHz -45 dB @ 20 kHz/ 25 kHz		
Audio Response	TIA603D		
Conducted Spurious Emission (TIA603D)	-57 dBm		

Transmitter	Full Keypad DP4801/DP4800	Limited Keypad DP4601/DP4600	Non Keypad DP4401/DP4400
Frequencies	VHF: 136 – 174 MHz UHF: 403 – 527 MHz		
Channel Spacing	12.5 kHz/ 20 kHz/ 25 kHz		
Frequency Stability (-30°C to +60°C)	+/-0.5 ppm		
Power Output (Low Power)	1 W		
Power Output (High Power)	VHF: 5 W UHF: 4 W		
Modulation Limiting	+/-2.5 kHz @ 12.5 kHz +/-4.0 kHz @ 20 kHz +/-5.0 kHz @ 25 kHz		
FM Hum and Noise	-40 dB @ 12.5 kHz -45 dB @ 20 kHz/ 25 kHz		
Conducted / Radiated Emission	-36 dBm < 1 GHz -30 dBm > 1 GHz		
Adjacent Channel Power	60 dB @ 12.5 kHz 70 dB @ 20 kHz/ 25 kHz		
Audio Response	TIA603D		
Audio Distortion	3%		
FM Modulation	12.5 kHz: 11K0F3E 25 kHz: 16K0F3E		
4FSK Digital Modulation	12.5 kHz Data Only: 7K60F1D & 7K60FXD 12.5 kHz Data & Voice: 7K60F1E & 7K60FXE Combination of 12.5 kHz Voice and Data: 7K60F1W		
Digital Vocoder Type	AMBE+2™		
Digital Protocol	ETSI-TS102361-1 ETSI-TS102361-2 ETSI-TS102361-3		

VHF Self-Quieter Frequencies	
with GOB	w/out GOB
139.2 +/- 10kHz	
141.6 +/- 10kHz	
143.36 +/- 10kHz	–
148.48 +/- 10kHz	
148.8 +/- 10kHz	
149.025 +/- 10kHz	–
150.525 +/- 10kHz	–
151 +/- 10kHz	–
151.74 +/- 10kHz	
152.575 +/- 10kHz	–
153.6 +/- 10kHz	
154.625 +/- 10kHz	–
156.675 +/- 10kHz	–
158.4 +/- 10kHz	
158.72 +/- 10kHz	
163.2 +/- 10kHz	
168 +/- 10kHz	
172.8 +/- 10kHz	

UHF Self-Quieter Frequencies	
with GOB	w/out GOB
403.200	
408.000 ± 10kHz	
412.800	
422.400	
431.615	–
432.000 ± 10kHz	
441.600	
444.000 ± 10kHz	–
449.550 ± 5kHz	
451.200	
456.000 ± 10kHz	
460.800	
468.735	–
470.400	
480.000 ± 10kHz	
494.400	
499.200	
504.000 ± 10kHz	
508.800	
518.400	

GPS	Full Keypad DP4801/DP4800	Limited Keypad DP4601/DP4600	Non Keypad DP4401/DP4400
TTFF (Time To First Fix) Cold Start	< 60 seconds)		
TTFF (Time To First Fix) Hot Start	≤ 10 seconds		
Horizontal Accuracy	< 5 meters		
Accuracy specs are for long-term tracking (95th percentile values > 5 satellites visible at a nominal -130 dBm signal strength)			

Bluetooth®	Display	Non-Display
Version	Supports Bluetooth 2.1+ EDR Specification	
Range	Class 2, 10 meters	

Military Standards										
Applicable MIL-STD	810C		810D		810E		810F		810G*	
	Methods	Procedures	Methods	Procedures	Methods	Procedures	Methods	Procedures	Methods	Procedures
Low Pressure	500.1	I	500.2	II	500.3	II	500.4	II	500.5	II
High Temperature	501.1	I, II	501.2	I/A1, II/A1	501.3	I-A1, II/A1	501.4	I/Hot, II/Hot	501.5	I/A1, II
Low Temperature	502.1	I	502.2	I/C3, II/C1	502.3	I-C3, II/C1	502.4	I-C3, II/C1	502.5	I, II
Temperature Shock	503.1	-	503.2	I/A1/C3	503.3	I/A1/C3	503.4	I	503.5	I-C
Solar Radiation	505.1	II	505.2	I	505.3	I	505.4	I	505.5	I-A1
Rain	506.1	I, II	506.2	I, II	506.3	I,II	506.4	I, III	506.5	I, III
Humidity	507.1	II	507.2	II	507.3	II	507.4	-	507.5	II
Salt fog	509.1	-	509.2	-	509.3	-	509.4	-	509.5	-
Dust	510.1	I	510.2	I	510.3	I	510.4	I	510.5	I
Vibration	514.2	VIII/F, Curve-W	514.3	I/10, II/3	514.4	I/10, II/3	514.5	I/24	514.6	II/5
Shock	516.2	I, II	516.3	I, IV	516.4	I, IV	516.5	I, IV	516.6	I, IV, VI

NOTE *Tested to MIL standard G which supersedes previous version

Environmental Specifications	
*Operating Temperature	-30 °C to +60 °C
Storage Temperature	-40 °C to +85 °C
Thermal Shock	Per MIL-STD
Humidity	Per MIL-STD
ESD	IEC 61000-4-2 Level 3
Water Intrusion	IEC 60529 -IP57

* Operating temperature specification with Lilon battery is -10 °C to +60 °C.
Operating temperature specification with NiMH battery is -20 °C to +60 °C.

Chapter 2 Test Equipment and Service Aids

2.1 Recommended Test Equipment

The list of equipment contained in Table 2-1 includes most of the standard test equipment required for servicing Motorola portable radios.

Table 2-1. Recommended Test Equipment

Equipment	Characteristics	Example	Application
Service Monitor	Can be used as a substitute for items marked with an asterisk (*)	Aeroflex 3920 (www.aeroflex.com),	Frequency/deviation meter and signal generator for wide-range troubleshooting and alignment
Digital RMS Multimeter *	100 μ V to 300 V 5 Hz to 1 MHz 10 Mega Ohm Impedance	Fluke 179 or equivalent (www.fluke.com)	AC/DC voltage and current measurements. Audio voltage measurements
RF Signal Generator *	100 MHz to 1 GHz -130 dBm to +10 dBm FM Modulation 0 kHz to 10 kHz Audio Frequency 100 Hz to 10 kHz	Agilent N5181A (www.agilent.com), Ramsey RSG1000B (www.ramseyelectronics.com), or equivalent	Receiver measurements
Oscilloscope *	2 Channel 50 MHz Bandwidth 5 mV/div to 20 V/div	Leader LS8050 (www.leaderusa.com), Tektronix TDS1001b (www.tektronix.com), or equivalent	Waveform measurements
Power Meter and Sensor *	5% Accuracy 100 MHz to 500 MHz 50 Watts	Bird 43 Thruline Watt Meter (www.bird-electronic.com) or equivalent	Transmitter power output measurements
RF Millivolt Meter	100 mV to 3 V RF 10 kHz to 1 GHz	Boonton 92EA (www.boonton.com) or equivalent	RF level measurements
Power Supply	0 V to 32 V 0 A to 20 A	B&K Precision 1790 (www.bkprecision.com) or equivalent	Voltage supply

2.2 Service Aids

Table 2-2 lists the service aids recommended for working on the radio. While all of these items are available from Motorola, most are standard workshop equipment items, and any equivalent item capable of the same performance may be substituted for the item listed.

Table 2-2. Service Aids

Motorola Part No.	Description	Application
RLN4460_	Portable Test Set	Enables connection to the audio/accessory jack. Allows switching for radio testing.
GMVN5141_	Customer Programming Software on CD-ROM	Allows servicer to program radio parameters, tune and troubleshoot radios.
PMKN4012B*	Portable Programming Cable	This cable connects the radio to a USB port for radio programming and data applications.
PMKN4013C*	Portable Programming, Testing & Alignment Cable	This cable connects the radio to a USB port for radio programming, testing and alignment.
PMNN4428_	7.5V Universal Battery Eliminator	Connects to radio via battery eliminator cable.
PMLN6154_	RF Adaptor	Adapts radio's antenna port to BNC cabling of test equipment.
PMLN6155_	RF Adaptor Holder	Holds RF connector to radio.
NLN9839_	Vacuum Pump Kit	Allows servicer to test for leakages.
NTN4265_	Pressure Pump Kit	Allows servicer to locate leakages.
5871134M01	Connector Fitting	This connector allows the vacuum hose to be connected to the radio chassis.
3271133M01	Fitting Seal	This seal secures the connector fitting to the radio chassis.

* Earlier versions of programming cables will not work with radio.

2.3 Programming, Testing and Alignment Cable

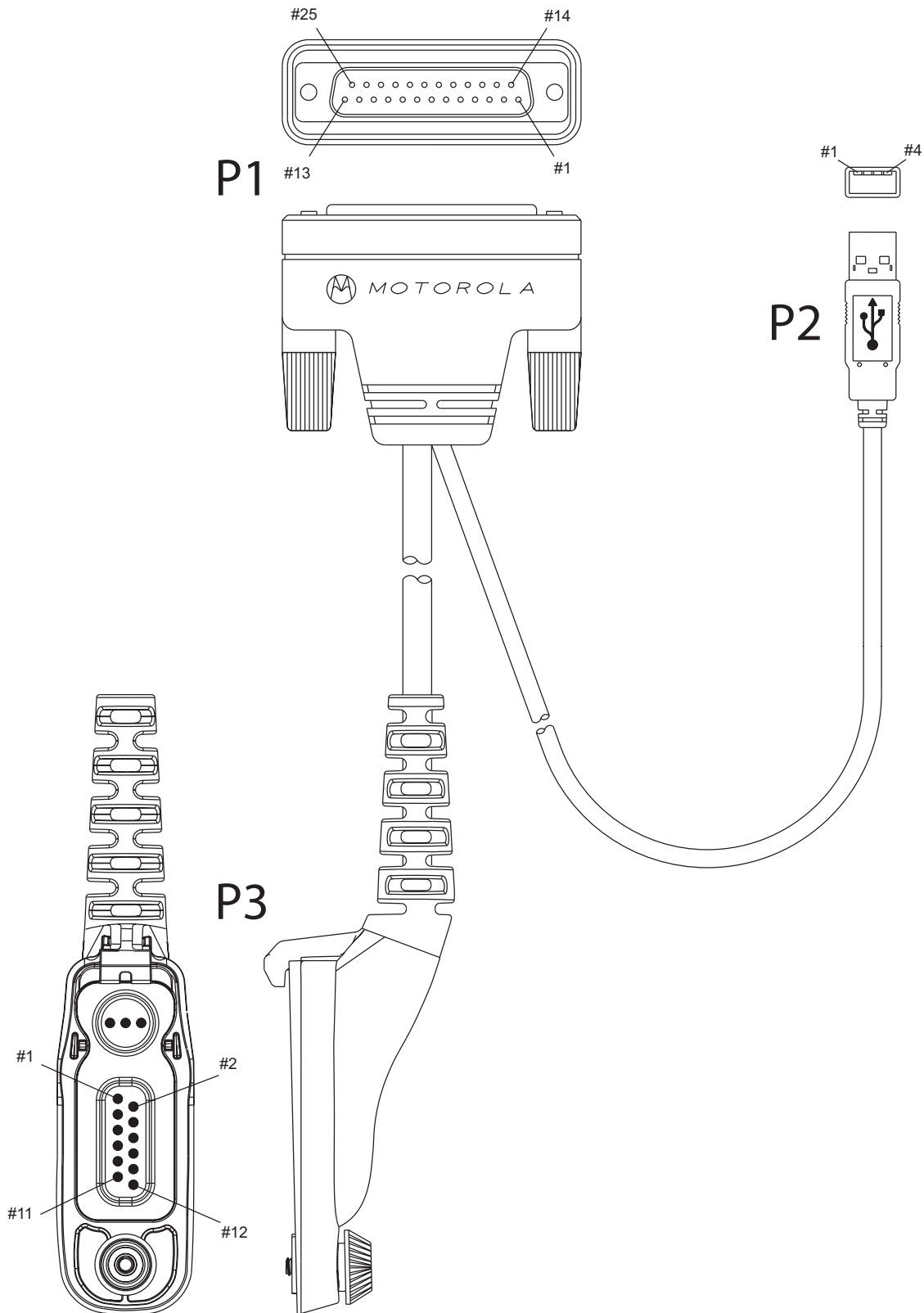

Figure 2-1. Programming, Testing and Alignment Cable

Table 2-3. Pin Configuration of Side Connector

CONNECTION			
P1	P2	P3	
Pin	Pin	Pin	Function
		1	GROUND
	1	3	VCC (5V)
	3	4	DATA+
	2	5	DATA-
16	4	6	GROUND
1 & 5		7	EXTERNAL SPEAKER+
2 & 7		8	EXTERNAL SPEAKER-
20		9	EXTERNAL PTT
17		10	EXTERNAL MIC+
16		11	EXTERNAL MIC-

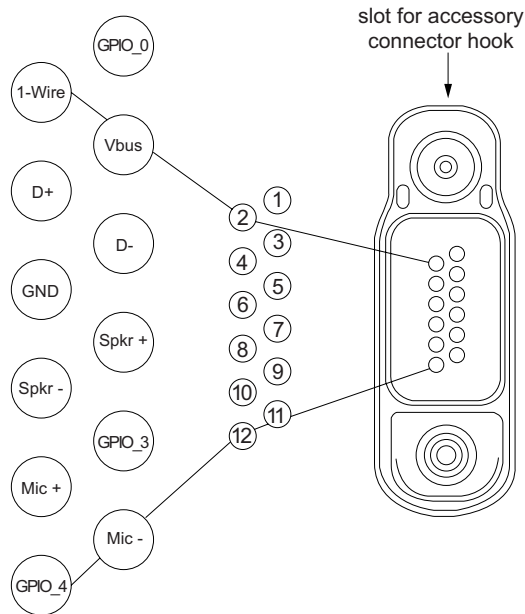

Figure 2-2. Pin Layout of Side Connector

Chapter 3 Transceiver Performance Testing

3.1 General

These radios meet published specifications through their manufacturing process by utilizing high-accuracy laboratory-quality test equipment. The recommended field service equipment approaches the accuracy of the manufacturing equipment with few exceptions. This accuracy must be maintained in compliance with the manufacturer's recommended calibration schedule.

Although these radios function in digital and analog modes, all testing is done in analog mode.

3.2 Setup

Supply voltage is provided using a 7.5 VDC power supply. The equipment required for alignment procedures is connected as shown in the Radio Tuning Equipment Setup Diagram, Figure 4-2.

 WARNING	Do NOT use any form of connector, e.g. wires, crocodile clips, and probes, to supply voltage to the radio, other than the Motorola approved battery eliminator.
--	--

Initial equipment control settings should be as indicated in Table 3-1. The remaining tables in this chapter contain the following related technical data:

Table Number	Title
3-2	Front Panel Access Test Mode Displays
3-3	Test Environments
3-4	Test Frequencies
3-5	Transmitter Performance Checks
3-6	Receiver Performance Checks

Table 3-1. Initial Equipment Control Settings

Service Monitor	Power Supply	Test Set
Monitor Mode: Power Monitor	Voltage: 7.5Vdc	Speaker set: A
RF Attn: -70	DC on/standby: Standby	Speaker/load: Speaker
AM, CW, FM: FM	Volt Range: 10V	PTT: OFF

Table 3-1. Initial Equipment Control Settings

Service Monitor	Power Supply	Test Set
Oscilloscope Source: Mod Oscilloscope Horizontal: 10mSec/Div Oscilloscope Vertical: 2.5kHz/Div Oscilloscope Trigger: Auto Monitor Image: Hi Monitor Bandwidth: Narrow Monitor Squelch: Middle setting Monitor Vol: 1/4 setting	Current: 2.5A	

3.3 Display Model Test Mode

3.3.1 Entering Display Radio Test Mode

1. Turn the radio on.
2. Within 10 seconds after Self Test is complete, press **Side Button 2** five times in succession
3. The radio beeps and will show a series of displays that will give information regarding various version numbers and subscriber specific information. The displays are described in Table 3-2.

Table 3-2. Front Panel Access Test Mode Displays

Name of Display	Description	Appears
Service Mode	The literal string indicates the radio has entered test mode.	Always
Host Version	The version of host firmware.	Always
DSP Version	The version of DSP firmware.	Always
Model Number	The radio's model number as programmed in the codeplug.	Always
MSN	The radio's serial number as programmed in the codeplug.	Always
FLASHCODE	The FLASH codes as programmed in the codeplug.	Always
RF Band	The radio's band.	Always

NOTE The radio stops at each display for 2 seconds before moving to the next information display. If the information cannot fit into 1 line, the radio display scrolls automatically character by character after 1 second to view the whole information. If the Left Navigation Key (◀) is pressed before the last information display, the radio shall suspend the information display until the user presses Right Navigation Key (▶) to resume the information display. The radio beeps for each button press. After the last display, RF Test Mode will be displayed.

3.3.2 RF Test Mode

When the radio is operating in its normal environment, the radio's microcontroller controls the RF channel selection, transmitter key-up, and receiver muting, according to the customer codeplug configuration. However, when the unit is on the bench for testing, alignment, or repair, it must be removed from its normal environment via a special routine, called **TEST MODE** or air test.

In RF Test Mode, the display upon the first line is "RF Test", together with the power level icon at the right end of the first line. The display upon the second line is the test environment, the channel number and channel spacing. The default test environment is CSQ.

1. Each short press of **Side Button 2** changes the test environment (CSQ->TPL->DIG->USQ ->CSQ). The radio beeps once when radio toggles to CSQ, beeps twice for TPL, beeps three times for DIG and beeps four times for USQ.

NOTE DIG is digital mode and other test environments are analog mode as described in Table 3-3.

Table 3-3. Test Environments

No. of Beeps	Description	Function
1	Carrier Squelch (CSQ)	RX: if carrier detected TX: mic audio
2	Tone Private-Line (TPL)	RX: unsquelch if carrier and tone detected TX: mic audio + tone
3	Digital Mode (DIG)	RX: if carrier detected TX: mic audio
4	Unsquelch (USQ)	RX: constant unsquelch TX: mic audio

- Each short press of **Side Button 1** toggles the channel spacing between 25 kHz, 12.5 kHz and 20 kHz as. The radio beeps once when radio toggles to 20kHz, beeps twice for 25 kHz and beeps three times for 12.5 kHz.
- Turning of the **Channel Knob** changes the test channel from 1 to 14 as described in Table 3-4. The radio beeps in each position.

Table 3-4. Test Frequencies

Channel Selector Switch Position	Test Channel	UHF	VHF
1 Low Power 9 High Power	TX#1 or #9 RX#1 or #9	403.15 403.15	136.075 136.075
2 Low Power 10 High Power	TX#2 or #10 RX#2 or #10	423.25 423.25	142.575 142.575
3 Low Power 11 High Power	TX#3 or #11 RX#3 or #11	444.35 444.35	146.575 146.575
4 Low Power 12 High Power	TX#4 or #12 RX#4 or #12	465.45 465.45	155.575 155.575
5 Low Power 13 High Power	TX#5 or #13 RX#5 or #13	485.55 485.55	161.575 161.575
6 Low Power 14 High Power	TX#6 or #14 RX#6 or #14	506.65 506.65	167.575 167.575
7 Low Power 15 High Power	TX#7 or #15 RX#7 or #15	526.75 526.75	173.975 173.975
8 Low Power 16 High Power	TX#8 or #16 RX#8 or #16	527.00 527.00	174.000 174.000

Table 3-5. Transmitter Performance Checks

Test Name	Communications Analyzer	Radio	Test Set	Comments
Reference Frequency	Mode: PWR MON 4th channel test frequency* Monitor: Frequency error Input at RF In/Out	TEST MODE, Test Channel 4 carrier squelch	PTT to continuously transmit (during the performance check)	Frequency error to be $\pm 604\text{Hz}$ for UHF $\pm 204\text{Hz}$ for VHF
Power RF	As above	As above	As above	Low Power: 1.0 – 1.6W (VHF/ UHF) High Power: 4.0 – 4.8W (UHF) High Power: 5.0 – 6.0W (VHF)
Voice Modulation	Mode: PWR MON 4th channel test frequency* atten to -70, input to RF In/Out Monitor: DVM: AC Volts Set 1kHz Mod Out level for 0.025Vrms at test set, 80mVrms at AC/DC test set jack	As above	As above, meter selector to mic	Deviation: $\geq 4.0\text{ kHz}$ but $\leq 5.0\text{ kHz}$ (25 kHz Ch Sp).
Voice Modulation (internal)	Mode: PWR MON 4th channel test frequency* atten to -70, input to RF In/Out	TEST MODE, Test Channel 4 carrier squelch output at antenna	Remove modulation input	Press PTT switch on radio. Say “four” loudly into the radio mic. Measure deviation: $\geq 4.0\text{ kHz}$ but $\leq 5.0\text{ kHz}$ (25 kHz Ch Sp)
TPL Modulation	As above 4th channel test frequency* BW to narrow	TEST MODE, Test Channel 4 TPL	As above	Deviation: $\geq 500\text{Hz}$ but $\leq 1000\text{Hz}$ (25 kHz Ch Sp).

* See Table 3-4

Table 3-6. Receiver Performance Checks

Test Name	Communications Analyzer	Radio	Test Set	Comments
Reference Frequency	Mode: PWR MON 4th channel test frequency* Monitor: Frequency error Input at RF In/Out	TEST MODE, Test Channel 4 carrier squelch output at antenna	PTT to continuously transmit (during the performance check)	Frequency error to be $\pm 604\text{Hz}$ for UHF $\pm 204\text{Hz}$ for VHF
Rated Audio	Mode: GEN Output level: 1.0mV RF 6th channel test frequency* Mod: 1kHz tone at 3kHz deviation Monitor: DVM: AC Volts	TEST MODE Test Channel 6 carrier squelch	PTT to OFF (center), meter selector to Audio PA	Set volume control to 2.83 Vrms Set volume control to 3.16 Vrms (IECEX/ CSA 800/900)
Distortion	As above, except to distortion	As above	As above	Distortion $< 3.0\%$
Sensitivity (SINAD)	As above, except SINAD, lower the RF level for 12dB SINAD.	As above	PTT to OFF (center)	RF input to be $< 0.35\mu\text{V}$
Noise Squelch Threshold (only radios with conventional system need to be tested)	RF level set to 1mV RF	As above	PTT to OFF (center), meter selection to Audio PA, speaker/load to speaker	Set volume control to 2.83Vrms Set volume control to 3.16 Vrms (IECEX/ CSA 800/900)
	As above, except change frequency to a conventional system. Raise RF level from zero until radio unsquelches.	Out of TEST MODE; select a conventional system	As above	Unsquelch to occur at $< 0.25\mu\text{V}$. Preferred SINAD = 9 – 10dB

* See Table 3-4

3.3.3 LED Test Mode

1. Press and hold **Side Button 1** after Display Test Mode. The radio beeps once and displays "LED Test Mode".
2. Upon any button/key press, the radio lights the red LED and displays "Red LED On".
3. Consequently, upon any button/key press, the red LED is turned off and the radio lights the green LED and displays "Green LED On".
4. Upon any successive button/key press, the green LED is turned off, and the radio shall light both LEDs up while displaying "Both LEDs On". Since there is only one LED on the portable, the LED color will be orange when the radio lights both LEDs.

3.3.4 Backlight Test Mode

1. Press and hold **Side Button 1** after LED Test Mode. The radio beeps once and displays "Backlight Test Mode".
2. The radio turns on both LCD and keypad backlight together.

3.3.5 Speaker Tone Test Mode

1. Press and hold **Side Button 1** after Backlight Test Mode. The radio beeps once and displays "Speaker Tone Test Mode".
2. The radio generates a 1 KHz tone with the internal speaker.

3.3.6 Earpiece Tone Test Mode

1. Press and hold **Side Button 1** after Speaker Tone Test Mode. The radio beeps once and displays "Earpiece Tone Test Mode".
2. The radio generates a 1 KHz tone with the earpiece.

3.3.7 Audio Loopback Earpiece Test Mode

1. Press and hold **Side Button 1** after Earpiece Tone Test Mode. The radio beeps once and displays "Audio Loopback Earpiece Test Mode".
2. The radio shall route any audio on the external mic to the earpiece.

3.3.8 Battery Check Test Mode

1. Press and hold **Side Button 1** after Audio Loopback Earpiece Test Mode. The radio beeps once and momentarily displays “Battery Check Test Mode”.
2. The radio will display the following:

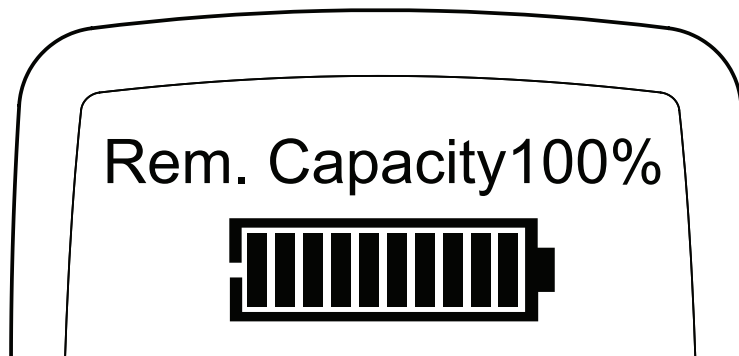

Figure 3-1. Battery Check Test Mode Display

3.3.9 Button/Knob/PTT Test Mode

1. Press and hold **Side Button 1** after Battery Check Test Mode. The radio beeps once and displays “Button Test”(line 1).
2. Rotate the **Volume Knob**; “2/1” through “2/255” appears. The radio beeps at each position.
3. Rotate the **Channel Knob**; When rotate the channel knob in clockwise, “4/1” appear. When rotate the channel knob in counter clockwise, “4/-1” appear. The radio beeps at each position.
4. Press **Side Button 1**; “96/1” appears & radio beeps; release, “96/0” appears & radio beeps.
5. Press **Side Button 2**; “97/1” appears & radio beeps; release, “97/0” appears & radio beeps.
6. Press **Side Button 3**; “98/1” appears & radio beeps; release, “98/0” appears & radio beeps.
7. Press the **PTT Switch**; “1/1” appears & radio beeps; release, “1/0” appears & radio beeps.
8. Press **Top Button**; “148/1” appears & radio beeps; release, “148/0” appears & radio beeps.
9. Keypad Checks:
 - Press **0**, “48/1” appears & radio beeps; release, “48/0” appears & radio beeps.
 - Press **1**, “49/1” appears & radio beeps; release, “49/0” appears & radio beeps.
 - Press **2**, “50/1” appears & radio beeps; release, “50/0” appears & radio beeps.
 - Press **3**, “51/1” appears & radio beeps; release, “51/0” appears & radio beeps.
 - Press **4**, “52/1” appears & radio beeps; release, “52/0” appears & radio beeps.
 - Press **5**, “53/1” appears & radio beeps; release, “53/0” appears & radio beeps.
 - Press **6**, “54/1” appears & radio beeps; release, “54/0” appears & radio beeps.
 - Press **7**, “55/1” appears & radio beeps; release, “55/0” appears & radio beeps.
 - Press **8**, “56/1” appears & radio beeps; release, “56/0” appears & radio beeps.
 - Press **9**, “57/1” appears & radio beeps; release, “57/0” appears & radio beeps.
 - Press *****, “58/1” appears & radio beeps; release, “58/0” appears & radio beeps.
 - Press **#**, “59/1” appears & radio beeps; release, “59/0” appears & radio beeps.
 - Press **P1**, “160/1” appears & radio beeps; release, “160/0” appears & radio beeps.
 - Press **P2**, “161/1” appears & radio beeps; release, “161/0” appears & radio beeps.
 - Press **MENU**, “85/1” appears & radio beeps; release, “85/0” appears & radio beeps.

- Press **BACK**, "129/1" appears & radio beeps; release, "129/0" appears & radio beeps.
- Press ◀, "128/1" appears & radio beeps; release, "128/0" appears & radio beeps.
- Press ▶, "130/1" appears & radio beeps; release, "130/0" appears & radio beeps.
- Press ▲, "135/1" appears & radio beeps; release, "135/0" appears & radio beeps.
- Press ▼, "136/1" appears & radio beeps; release, "136/0" appears & radio beeps.

3.4 Display Model Test Mode

3.4.1 Monochrome Display Test

1. Press any button to test the LCD display, press button ">" until the display are fixed. Then, press and hold the first side button until the screen change.
2. Upon any button/key press, the LCD shall display the growing horizontal bars. Press button ▶ until the LCD display full screen in Black and change to vertical bars.
3. Press button ▶ until the LCD display full screen Black and change to icon display.
4. The LCD shall display RSSI icon (with full bar), monitor icon, high power level icon (H), tone disabled icon, priority-two channel scan icon, option board icon, unread message icon, emergency icon, talkaround icon, and battery strength indicator icon (with full bar).
5. The LCD shall clear the screen and display the rest of the icons (low power level icon (L), companding icon, and secure operation icon) upon any button/key press.
6. Then, press and hold the first side button until the screen change.

3.4.2 Color Display Test

1. Press any button to test the LCD display, press button ▶ until the display are fixed. Then, press and hold the first side button until the screen change.
2. Upon key ▶ press, the housing shall display a White screen with 2 pixels wide of a black border inset from the edge by 2 pixels and the text "Display Test Mode" in black.
3. Upon key ▶ press, the housing shall display a Black screen with 2 pixels wide of a White boarder inset from the edge by 2 pixels and the text "Display Test Mode" in White.
4. Upon key ▶ press, the housing shall display a full screen in Red.
5. Upon key ▶ press, the housing shall display a full screen in Green.
6. Upon key ▶ press, the housing shall display a full screen in Blue.
7. Upon key ▶ press, the housing shall display the growing horizontal bars with a cyclic color of Red>Green>Blue>Black>Red>Green>Blue>Black>Red (Full Screen).
8. Upon key ▶ press, the housing shall display the growing vertical bars with a cyclic color of Red>Green>Blue>Black>Red>Black (Full Screen).
9. Upon key ">"press, until all icons in color show. The housing shall display RSSI icon (with full bar), monitor icon, high power level icon (H), tone disabled icon, priority-two channel scan icon, option board icon, unread message icon, emergency icon, talkaround icon, and battery strength indicator icon (with full bar).
10. The housing shall clear the screen and display the rest of the icons in color, (low power level icon (L), companding icon, and secure operation icon) upon key ">"press. Then, press and hold the first side button until the screen change.

3.5 Non-Display Model Test Mode

3.5.1 Entering Non-Display Radio Test Mode

1. Turn the radio on.
2. Within 10 seconds after “Self Test” is complete, press **Side Button 2** five times in succession.
3. The radio beeps.

3.5.2 RF Test Mode

When the radio is operating in its normal environment, the radio's microcontroller controls the RF channel selection, transmitter key-up, and receiver muting, according to the customer codeplug configuration. However, when the unit is on the bench for testing, alignment, or repair, it must be removed from its normal environment via a special routine, called **TEST MODE** or “air test”.

1. Each short press of **Side Button 2** changes the test environment (CSQ->TPL->DIG->USQ->CSQ). The radio beeps once when radio toggles to CSQ, beeps twice for TPL, beeps three times for DIG and beeps four times for USQ.

NOTE DIG is digital mode and other test environments are analog mode as described in Table 3-3.

2. Each short press of **Side Button 1** toggles the channel spacing between 25 KHz, 12.5 KHz and 20 KHz as. The radio beeps once when radio toggles to 20KHz, beeps twice for 25KHz and beeps three times for 12.5KHz.
3. Turning of the **Channel Knob** changes the test channel from 1 to 14 as described in Table 3-4. The radio beeps in each position.

3.5.3 LED Test Mode

1. Press and hold **Side Button 1** in RF Test Mode. The radio beeps once.
2. Upon any button/key press, the radio lights up the red LED.
3. Consequently, upon any button/key press, the red LED is turned off and the radio turns on the green LED.
4. Consequently, upon any button/key press, the green LED is turned off the radio shall turn on both LEDs.

3.5.4 Speaker Tone Test Mode

1. Press and hold **Side Button 1** after LED Test Mode. The radio beeps once.
2. The radio generates a 1 KHz tone with the internal speaker.

3.5.5 Earpiece Tone Test Mode

1. Press and hold **Side Button 1** after Speaker Tone Test Mode. The radio beeps once.
2. The radio generates a 1 KHz tone with the earpiece.

3.5.6 Audio Loopback Earpiece Test Mode

1. Press and hold **Side Button 1** after Earpiece Tone Test Mode. The radio beeps once.
2. The radio shall route any audio on the external mic to the earpiece.

3.5.7 Battery Check Test Mode

1. Press and hold **Side Button 1** after Audio Loopback Earpiece Test Mode. The radio beeps once.
2. The radio LED lights up accordingly; green LED for High Battery Level, orange LED for Mid Battery Level and blinking red LED for Low Battery Level.

3.5.8 Button/Knob/PTT Test Mode

1. Press and hold **Side Button 1** after Battery Check Test Mode. The radio beeps once.
2. Rotate the **Volume Knob**; the radio beeps at each position.
3. Rotate the **Channel Knob**; the radio beeps at each position.
4. Press **Side Button 1**; the radio beeps; release, the radio beeps.
5. Press **Side Button 2**; the radio beeps; release, the radio beeps.
6. Press **Side Button 3**; the radio beeps; release, the radio beeps.
7. Press the **PTT Switch**; the radio beeps; release, the radio beeps.
8. Press **Top Button**; the radio beeps; release, the radio beeps.

Notes

Chapter 4 Radio Programming and Tuning

4.1 Introduction

This chapter provides an overview of the MOTOTRBO Customer Programming Software (CPS), as well as the Tuner and AirTracer applications, which are all designed for use in a Windows 2000/XP/Windows 7 environment. These programs are available in one kit as listed in Table 4-1. An Installation Guide is also included with the kit.

NOTE Refer to the appropriate program on-line help files for the programming procedures.

Table 4-1. Software Installation Kits Radio Tuning Setup

Description
MOTOTRBO CPS, Tuner and AirTracer Applications CD

4.2 Customer Programming Software Setup

The CPS programming setup, shown in Figure 4-1 is used to program the radio.

NOTE Refer to appropriate program on-line help files for the programming procedures.



Caution Computer USB ports can be sensitive to Electrostatic Discharge. Do not touch exposed contacts on cable when connected to a computer.

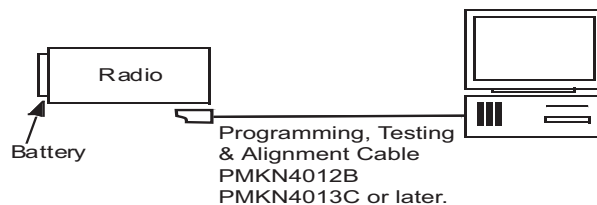

Figure 4-1. CPS Programming Setup

4.3 AirTracer Application Tool

The MOTOTRBO AirTracer application tool has the ability to capture over-the-air digital radio traffic and save the captured data into a file. The AirTracer application tool can also retrieve and save

internal error logs from MOTOTRBO radios. The saved files can be analyzed by trained Motorola personnel to suggest improvements in system configurations or to help isolate problems.

4.4 Radio Tuning Setup

A personal computer (PC), Windows 2000/XP/Windows 7 and a tuner program are required to tune the radio. To perform the tuning procedures, the radio must be connected to the PC, radio interface box (RIB), and test equipment setup as shown in Figure 4-2.

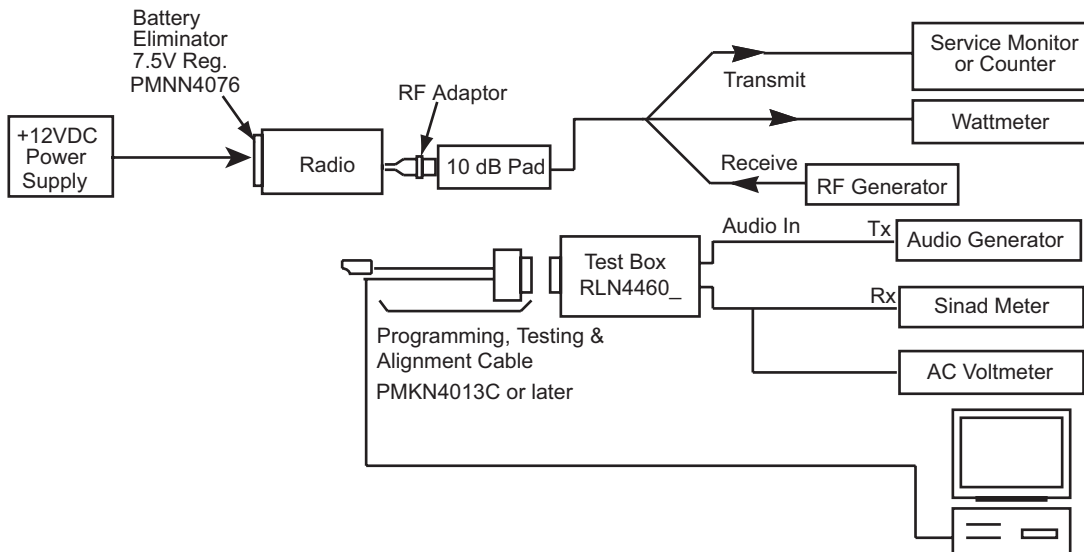

Figure 4-2. Radio Tuning Equipment Setup

Chapter 5 Disassembly/Reassembly Procedures

5.1 Introduction

This chapter provides details about the following:

- Preventive maintenance (inspection and cleaning).
- Safe handling of CMOS and LDMOS devices.
- Disassembly and reassembly of the radio.
- Repair procedures and techniques.

5.2 Preventive Maintenance

Periodic visual inspection and cleaning is recommended.

5.2.1 Inspection

Check that the external surfaces of the radio are clean, and that all external controls and switches are functional. It is not recommended to inspect the interior electronic circuitry.

5.2.2 Cleaning Procedures

The following procedures describe the recommended cleaning agents and the methods to be used when cleaning the external and internal surfaces of the radio. External surfaces include the front cover, housing assembly and battery case. These surfaces should be cleaned whenever a periodic visual inspection reveals the presence of smudges, grease, and/or grime.

NOTE Internal surfaces should be cleaned only when the radio is disassembled for service or repair.

The only recommended agent for cleaning the external radio surfaces is a 0.5% solution of a mild dishwashing detergent in water. The only factory recommended liquid for cleaning the printed circuit boards and their components is isopropyl alcohol (100% by volume).



Caution

The effects of certain chemicals and their vapors can have harmful results on certain plastics. Avoid using aerosol sprays, tuner cleaners and other chemicals.

Cleaning External Plastic Surfaces

Apply the 0.5% detergent-water solution sparingly with a stiff, non-metallic, short-bristled brush to work all loose dirt away from the radio. Use a soft, absorbent, lintless cloth or tissue to remove the solution and dry the radio. Make sure that no water remains entrapped near the connectors, cracks, or crevices.

Cleaning Internal Circuit Boards and Components

Isopropyl alcohol (100%) may be applied with a stiff, non-metallic, short-bristled brush to dislodge embedded or caked materials located in hard-to-reach areas. The brush stroke should direct the dislodged material out and away from the inside of the radio. Make sure that controls or tunable components are not soaked with alcohol. Do not use high-pressure air to hasten the drying process since this could cause the liquid to collect in unwanted places. After completing of the cleaning process, use a soft, absorbent, lintless cloth to dry the area. Do not brush or apply any isopropyl alcohol to the frame, front cover or back cover.

NOTE Always use a fresh supply of alcohol and a clean container to prevent contamination by dissolved material (from previous usage).



Caution

Use all chemicals as prescribed by the manufacturer. Be sure to follow all safety precautions as defined on the label or material safety data sheet.

5.3 Safe Handling of CMOS and LDMOS Devices

Complementary metal-oxide semiconductor (CMOS) devices are used in this family of radios, and are susceptible to damage by electrostatic or high voltage charges. Damage can be latent, resulting in failures occurring weeks or months later. Therefore, special precautions must be taken to prevent device damage during disassembly, troubleshooting, and repair.

Handling precautions are mandatory for CMOS circuits and are especially important in low humidity conditions. DO NOT attempt to disassemble the radio without first referring to the CMOS CAUTION paragraph in the Disassembly and Reassembly section of the manual.

DO NOT attempt to disassemble the radio without first referring to the following CAUTION statement.



Caution

This radio contains static-sensitive devices. Do not open the radio unless you are properly grounded. Take the following precautions when working on this unit:

- Store and transport all CMOS/LDMOS devices in conductive material so that all exposed leads are shorted together. Do not insert CMOS/LDMOS devices into conventional plastic “snow” trays used for storage and transportation of other semiconductor devices.
- Ground the working surface of the service bench to protect the CMOS/LDMOS device. We recommend using the Motorola Static Protection Assembly (part number 0180386A82), which includes a wrist strap, two ground cords, a table mat, and a floor mat, ESD shoes and an ESD chair.
- Wear a conductive wrist strap in series with a 100k resistor to ground. (Replacement wrist straps that connect to the bench top covering are Motorola part number 4280385A59).
- Do not wear nylon clothing while handling CMOS/LDMOS devices.
- Do not insert or remove CMOS/LDMOS devices with power applied. Check all power supplies used for testing CMOS/LDMOS devices to be certain that there are no voltage transients present.
- When straightening CMOS/LDMOS pins, provide ground straps for the apparatus used.
- When soldering, use a grounded soldering iron.
- If at all possible, handle CMOS/LDMOS devices by the package and not by the leads. Prior to touching the unit, touch an electrical ground to remove any static charge that you may have accumulated. The package and substrate may be electrically common. If so, the reaction of a discharge to the case would cause the same damage as touching the leads.

5.4 Repair Procedures and Techniques – General

NOTE Environmentally Preferred Products (EPP) (refer to the marking on the printed circuit boards — examples shown below) were developed and assembled using environmentally preferred components and solder assembly techniques to comply with the European Union's **Restriction of Hazardous Substances (ROHS) Directive 2002/95/EC** and **Waste Electrical and Electronic Equipment (WEEE) Directive 2002/96/EC**. To maintain product compliance and reliability, use only the Motorola specified parts in this manual.

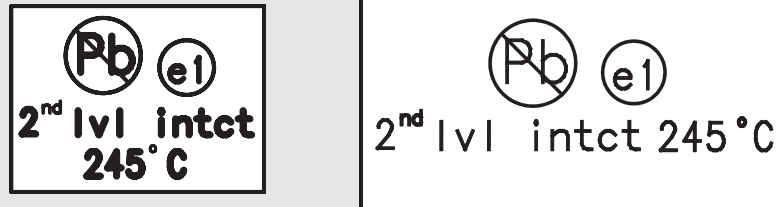

Any rework or repair on Environmentally Preferred Products must be done using the appropriate lead-free solder wire and lead-free solder paste as stated in the following table:

Table 5-1. Lead Free Solder Wire Part Number List

Motorola Part Number	Alloy	Flux Type	Flux Content by Weight	Melting Point	Supplier Part number	Diameter	Weight
1088929Y01	95.5Sn/3.8Ag/0.7Cu	RMA Version	2.7-3.2%	217C	52171	0.015"	1lb spool

Table 5-2. Lead Free Solder Paste Part Number List

Motorola Part Number	Manufacturer Part Number	Viscosity	Type	Composition & Percent Metal	Liquid Temperature
1085674C03	NC-SMQ230	900-1000KCPs Brookfield (5rpm)	Type 3 (-325/+500)	(95.5%Sn-3.8%Ag-0.7%Cu) 89.3%	217°C

Parts Replacement and Substitution

When damaged parts are replaced, identical parts should be used. If the identical replacement part is not locally available, check the parts list for the proper Motorola part number and order the part

Rigid Circuit Boards

This family of radios uses bonded, multi-layer, printed circuit boards. Since the inner layers are not accessible, some special considerations are required when soldering and unsoldering components. The printed-through holes may interconnect multiple layers of the printed circuit. Therefore, exercise care to avoid pulling the plated circuit out of the hole.

When soldering near a connector:

- Avoid accidentally getting solder in the connector.
- Be careful not to form solder bridges between the connector pins.
- Examine your work closely for shorts due to solder bridges.

5.5 Disassembling and Reassembling the Radio — General

When disassembling and reassembling the radio, it is important to pay particular attention to the snaps and tabs, and how parts align with each other.

The following tools are required for disassembling the radio:

- TORX™ T3 and T6 screwdriver
- Chassis and Knob Opener (PMLN6208_)

The following item and tools are required for reassembling the radio:

- Grease (1185937A01)
- TORX™ T3 and T6 screwdriver
- Vacuum Pump Kit (NLN9839) - Radio Immersibility Test
- Pressure Pump Kit (NTN4265) - Radio Immersibility Test
- Connector Fitting (5871134M01) - Radio Immersibility Test
- Fitting Seal (3271133M01) - Radio Immersibility Test
- Seal Port (3286058L01)
- Label Ventilation (5478220A01)

If a unit requires further testing or service than is customarily performed at the basic level, please send the radio to a Motorola Service Center.

5.6 Radio Disassembly – Detailed

5.6.1 Front Cover from Chassis Disassembly

1. Turn off the radio.
2. Remove the battery:
 - a. Release the battery latch by moving it into the unlock position.
 - b. With the latch released, slide the battery downwards.
 - c. Remove the battery from the radio.
3. Remove the antenna by turning it counterclockwise.

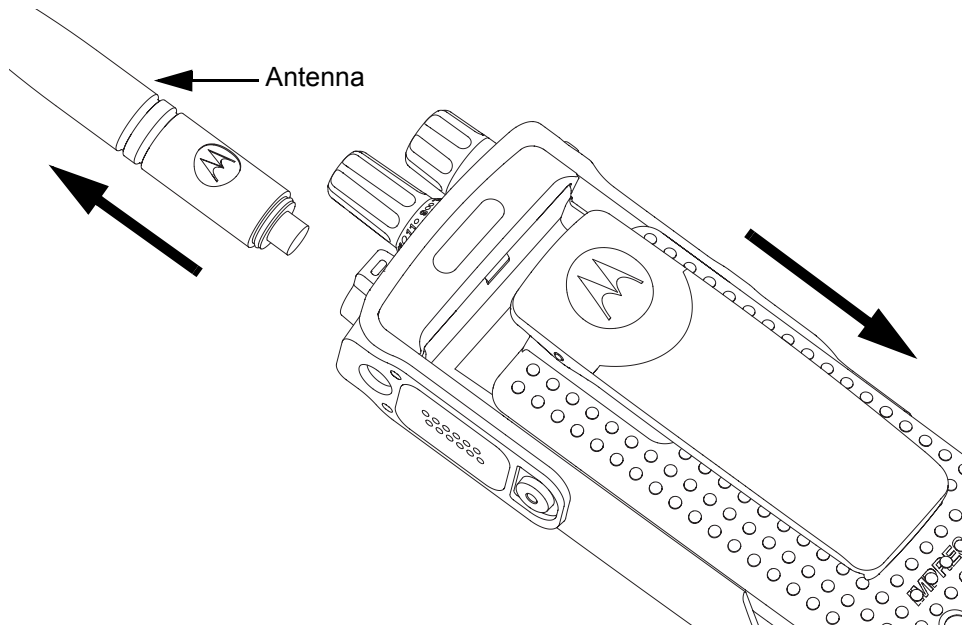

Figure 5-1. Antenna and Battery removal.

4. Remove the channel selector knob and volum knob off from their shafts using the knob removal tool.

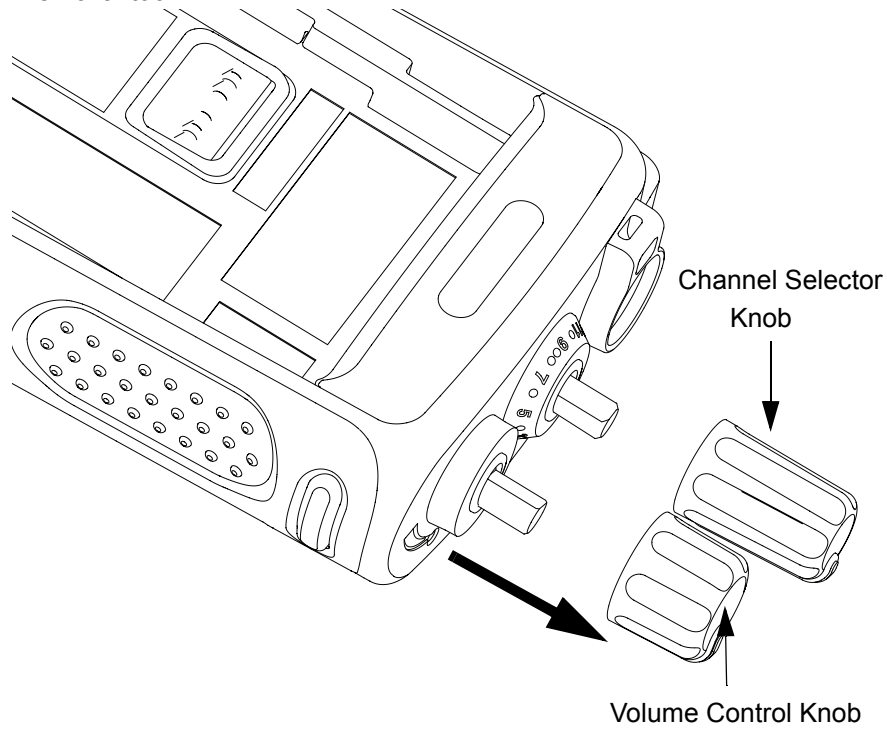

Figure 5-2. Channel Selector and Volume Knob removal.

NOTE Both knobs slide on and off. However, they are supposed to fit very tightly on their shafts.

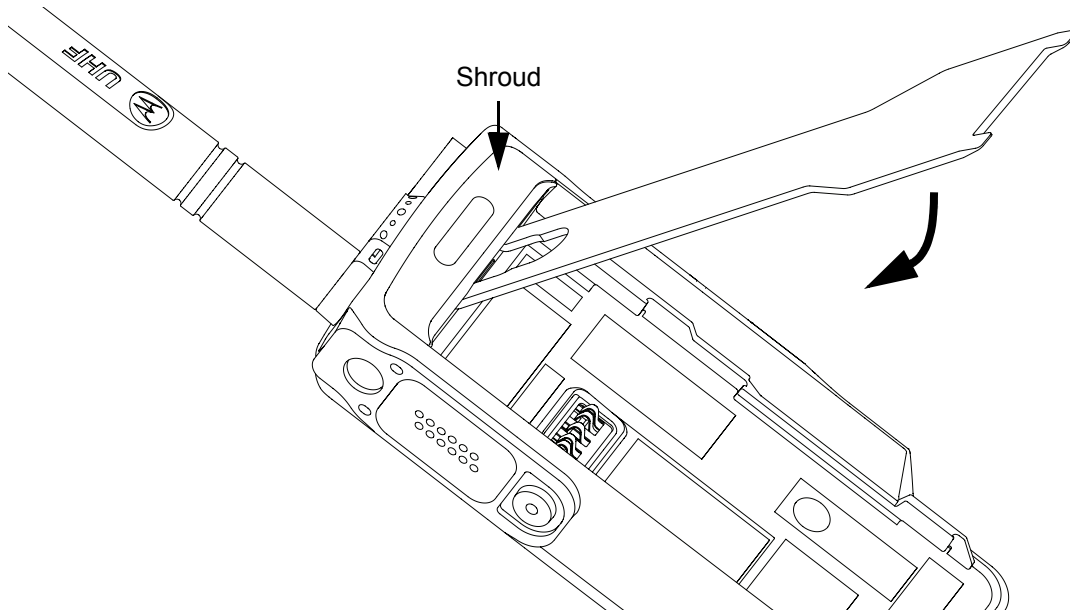

Figure 5-3. Shroud removal

5. Hook the knob opener under the shroud as shown in Figure 5-5 and detach it with a downward motion.
6. Separate the chassis from the housing assembly as follows:
 - a. Insert the chassis opener into the recess at the bottom of the radio. Apply a downward force to separate the chassis from the front housing.
 - b. Remove the chassis from the front housing.

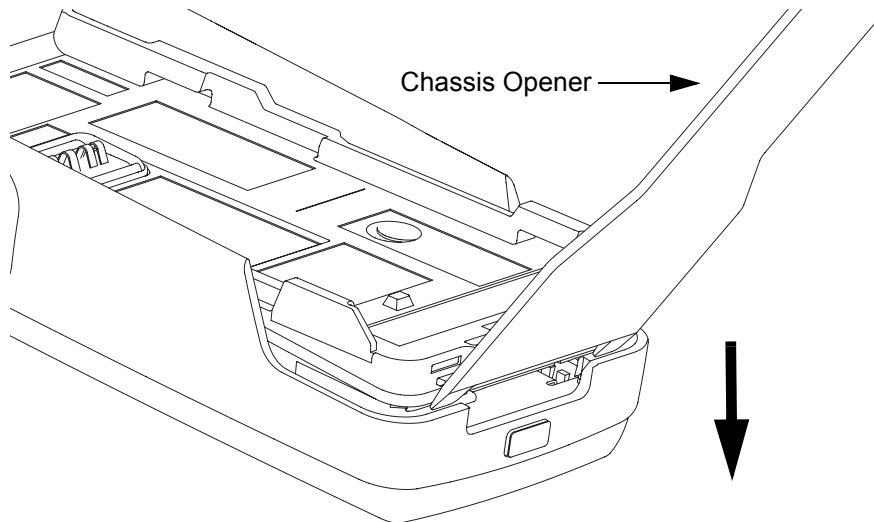

Figure 5-4. Chassis removal

7. Lay the chassis down. Rotate the front cover backward and slightly away from the chassis.

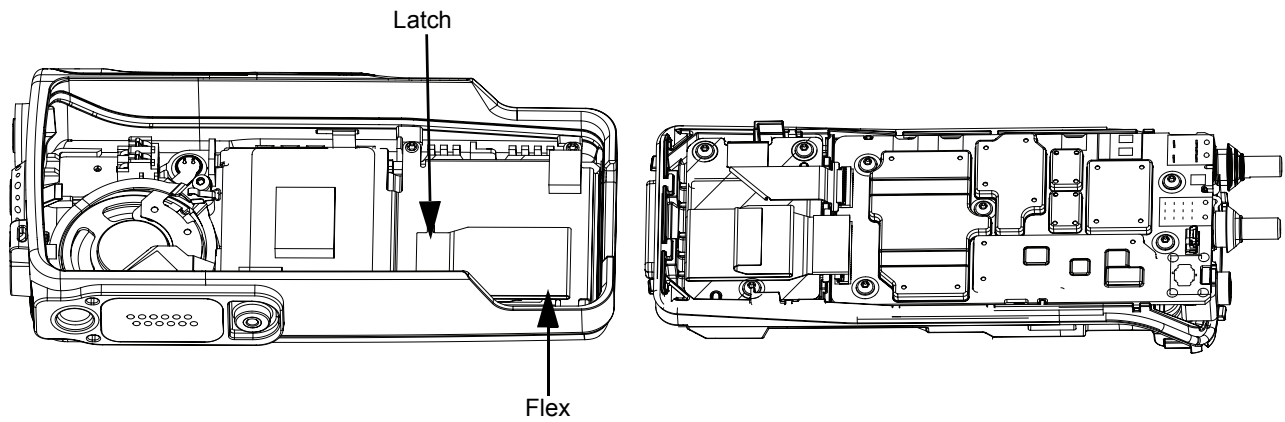

Figure 5-5. Disconnecting the chassis

8. Lift the latch on the main board to release the keypad from its connector.
9. Remove the flex from the keypad board by pulling it out of its connector gently.
10. Lift the latch on the main board to release the GOB flex from its connector.

5.6.2 Chassis Disassembly

Use a TORX screwdriver with a T6 head to remove the five screws holding the main board to the chassis and the three screws holding the GOB.

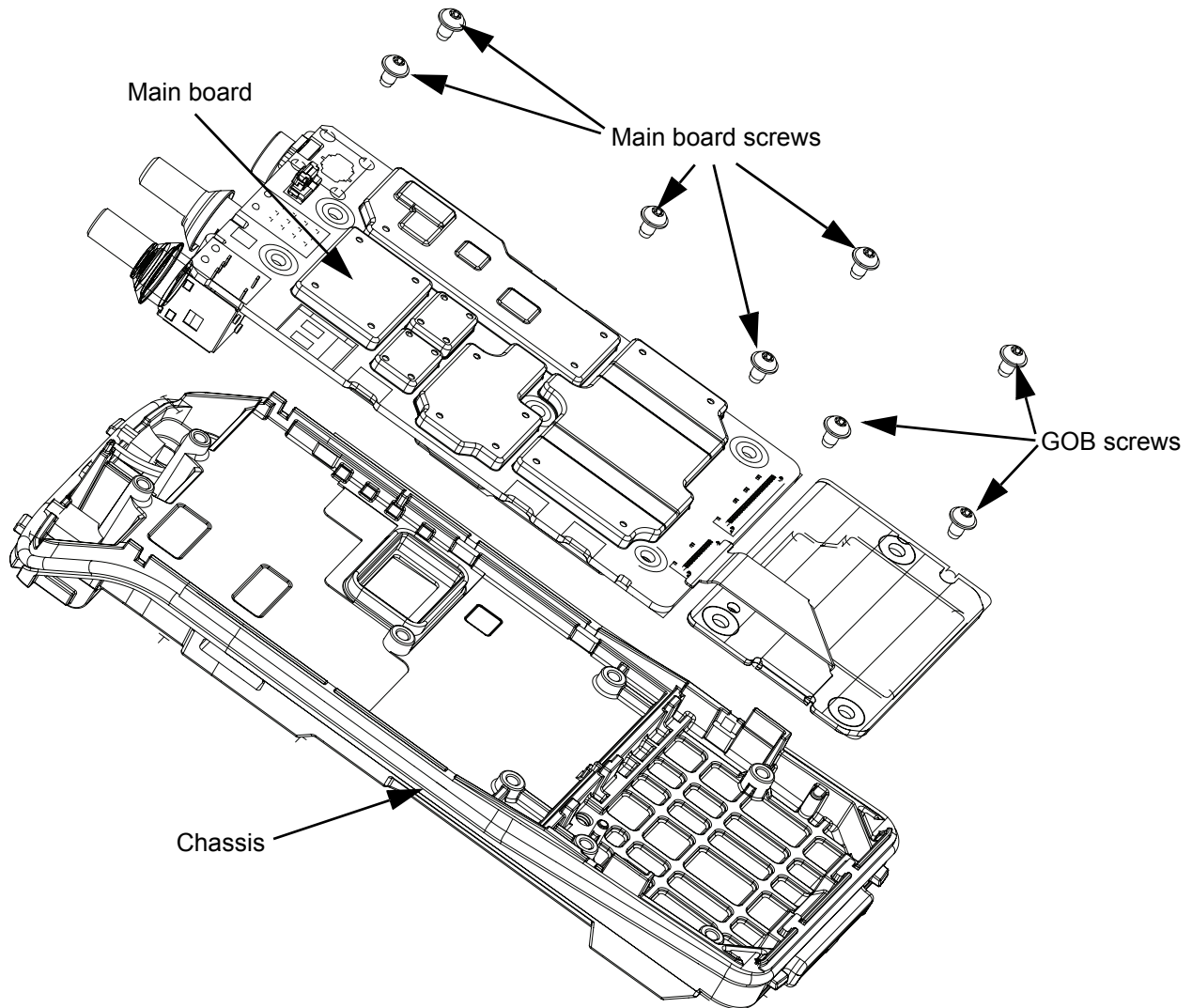

Figure 5-6. Chassis disassembly

1. Lift the main board from the chassis.
2. Lift the latch to separate the flex for the GOB.
3. Lift the GOB from the chassis.
4. Release all the tabs from the catches.
5. Remove the O-ring and battery contact seal

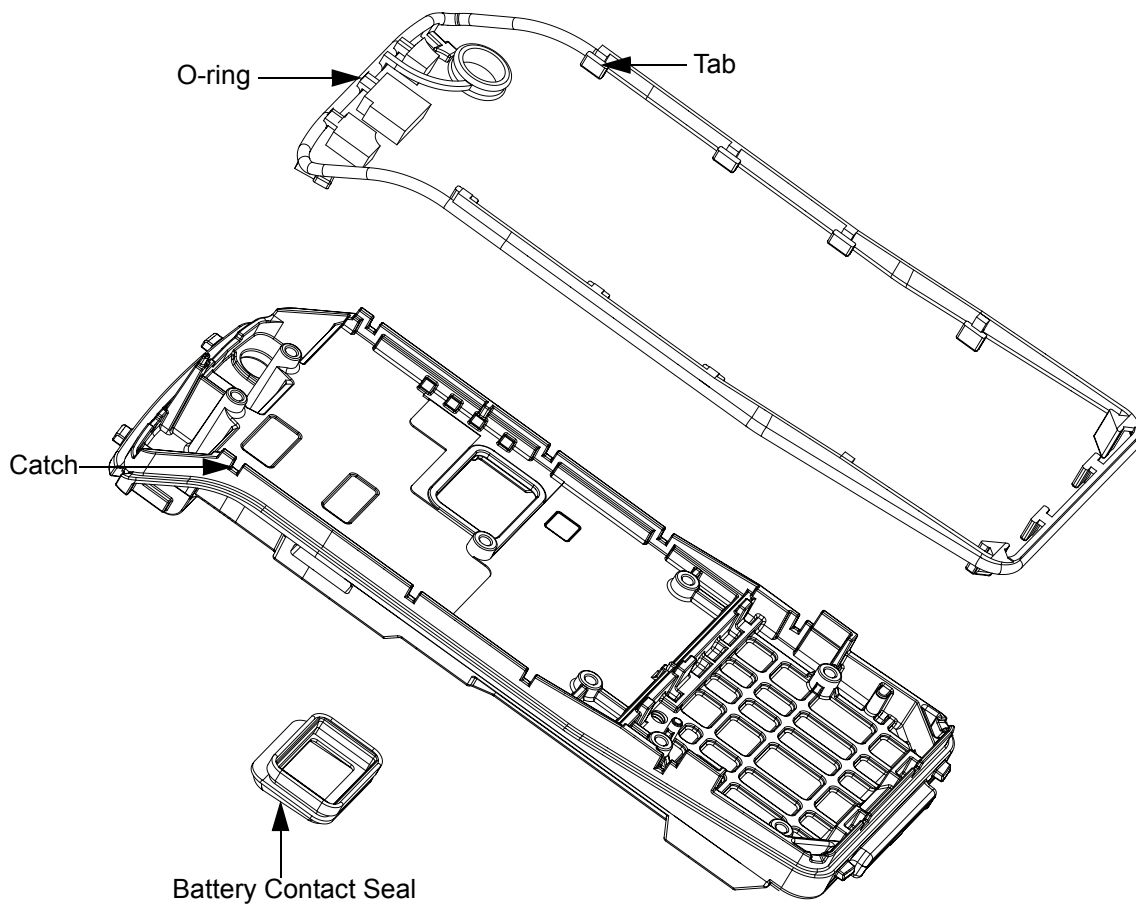

Figure 5-7. O-ring removal

5.6.3 Keypad, Display, and Keypad Board Disassembly

1. If the disassembly of the keypad, the keypad printed circuit board, or the display is required, remove the retainer by using a TORX screwdriver with a T6 head to remove the four screws.
2. Slide out the retainer from the housing assembly.
3. Disconnect the speaker flex, LCD flex and PTT flex from the keypad board.

NOTE The LCD, keypad board and keypad can be removed without the use of tools.

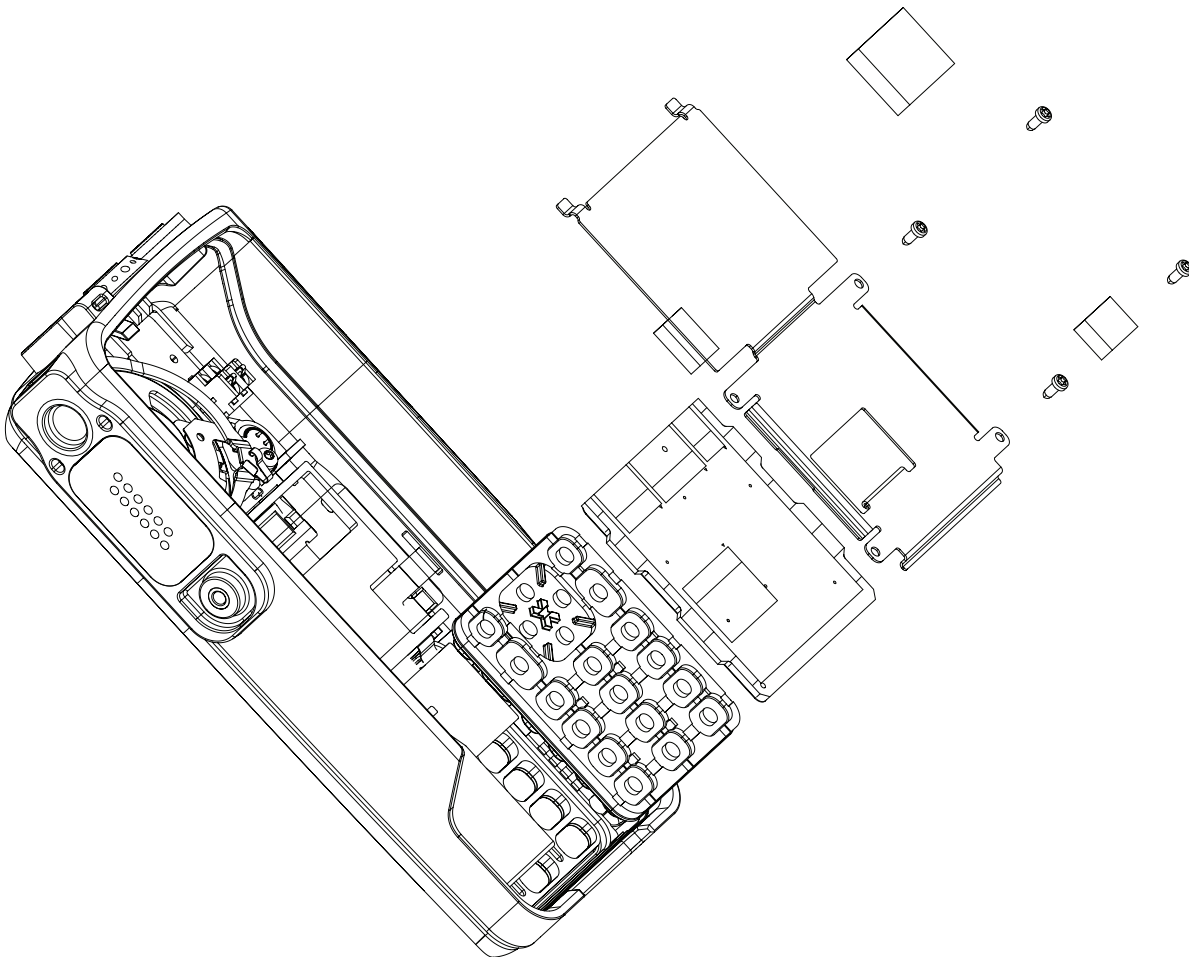

Figure 5-8. Keypad, Display, and Keypad Board disassembly for Full Keypad

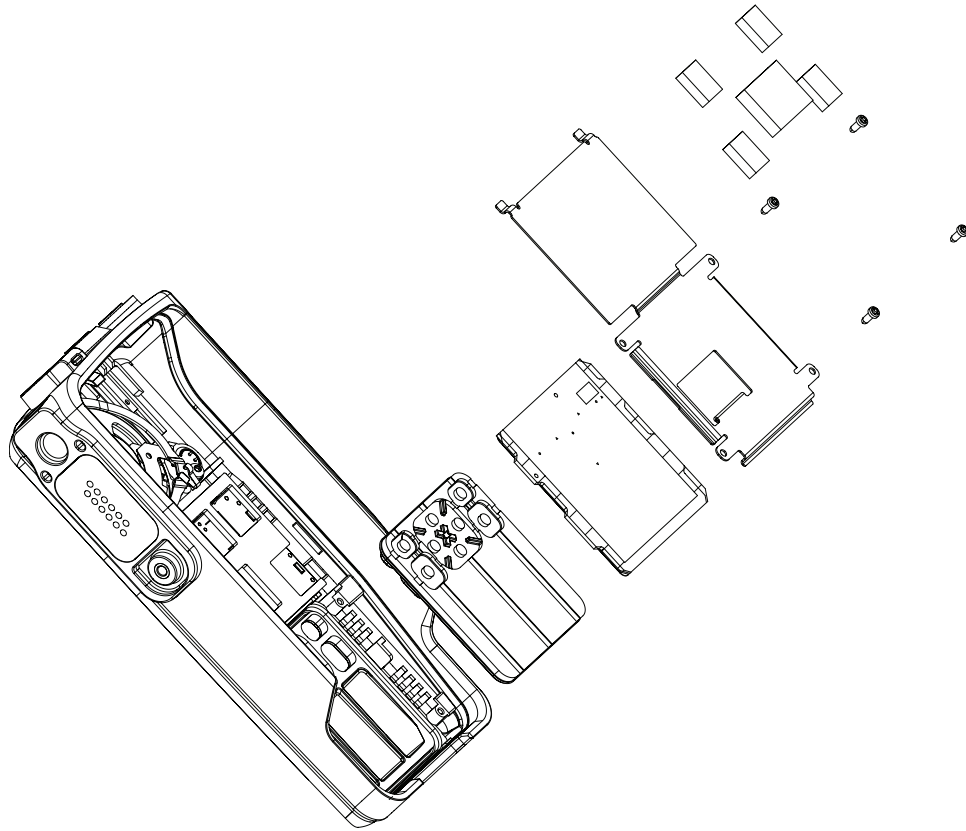

Figure 5-9. Keypad, Display, and Keypad Board Disassembly for Limited Keypad

5.6.4 Speaker, Microphone, and Universal Connector Flex Disassembly

1. Pull the microphone boot from its seated position.
2. Remove the speaker retainer screw using the TORX T6 screwdriver.
3. Peel-off the universal connector flex circuit escutcheon.
4. Pull the UC flex circuit (adhesive held) backer board from the front cover. Push the universal connector flex through the UC slot into the housing.
5. Remove the speaker retainer from the speaker assembly.
6. Remove the assembly from the front housing.

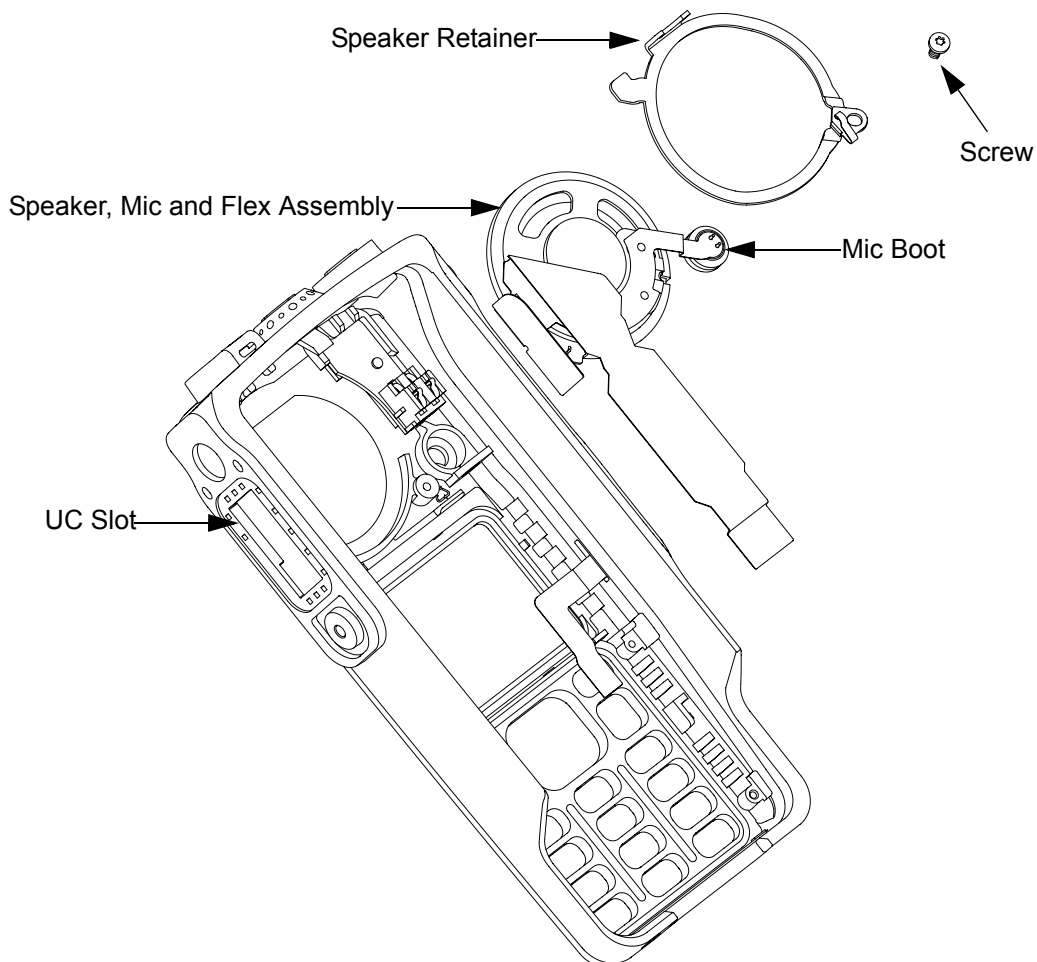

Figure 5-10. Speaker removal for Full Keypad

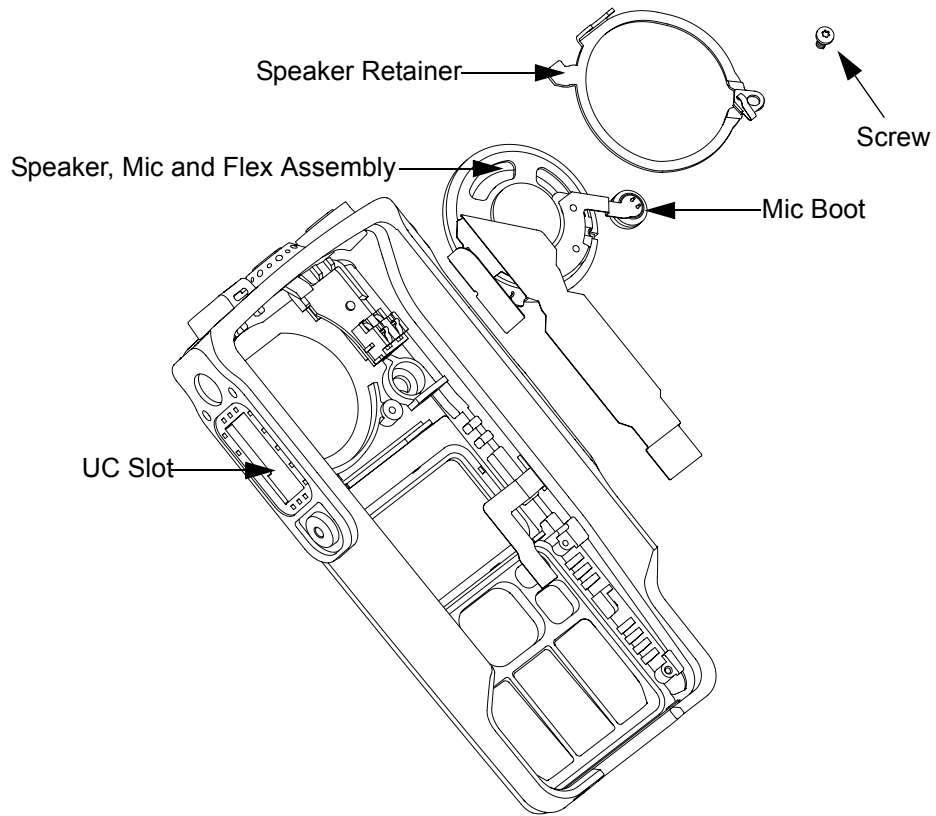

Figure 5-11. Speaker removal for Limited Keypad

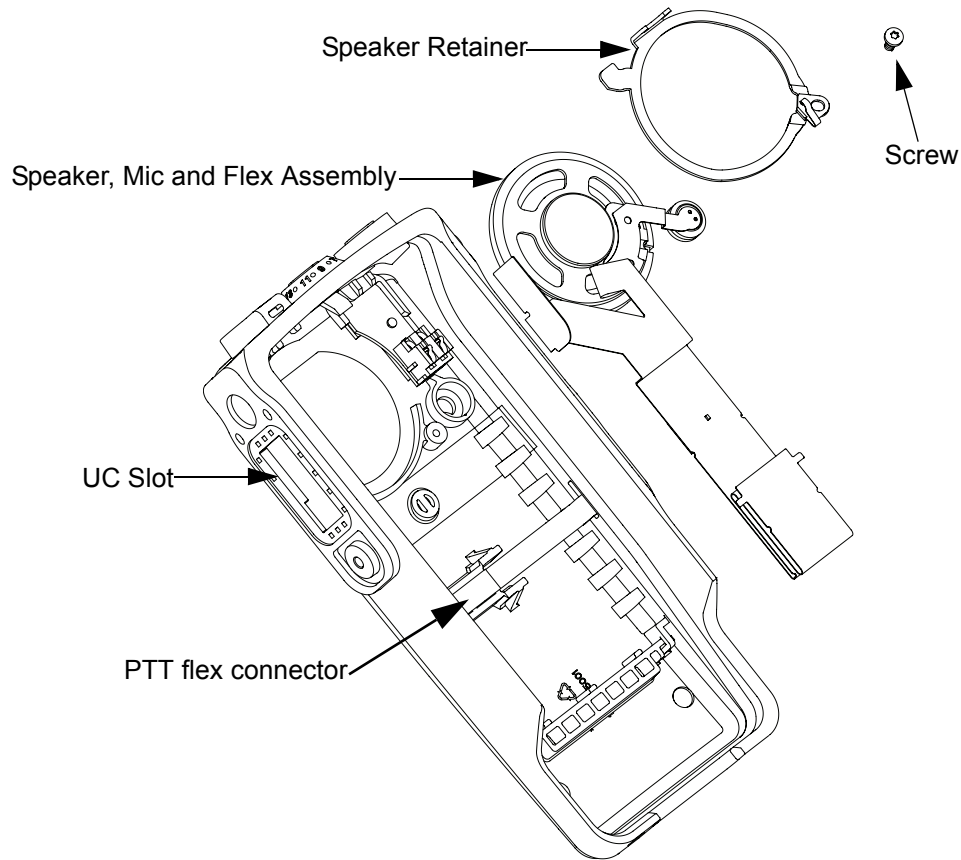

Figure 5-12. Speaker removal for Non-Keypad

1. Pull the rubber microphone boot from its seated position.
2. Remove the screw using the TORX T6 screwdriver.
3. Disconnect the PTT flex and peel the speaker assembly flex from the housing.
4. Peel off the universal connector flex circuit escutcheon.
5. Pull the UC flex circuit (adhesive held) backer board from the front cover. Push the universal connector flex through the UC slot into the housing.
6. Remove the speaker retainer from the speaker assembly.
7. Remove the assembly from the front housing.

5.6.5 Emergency Button Assembly Dissassembly

1. The Emergency button can be removed without the use of tools once the speaker retainer is removed.

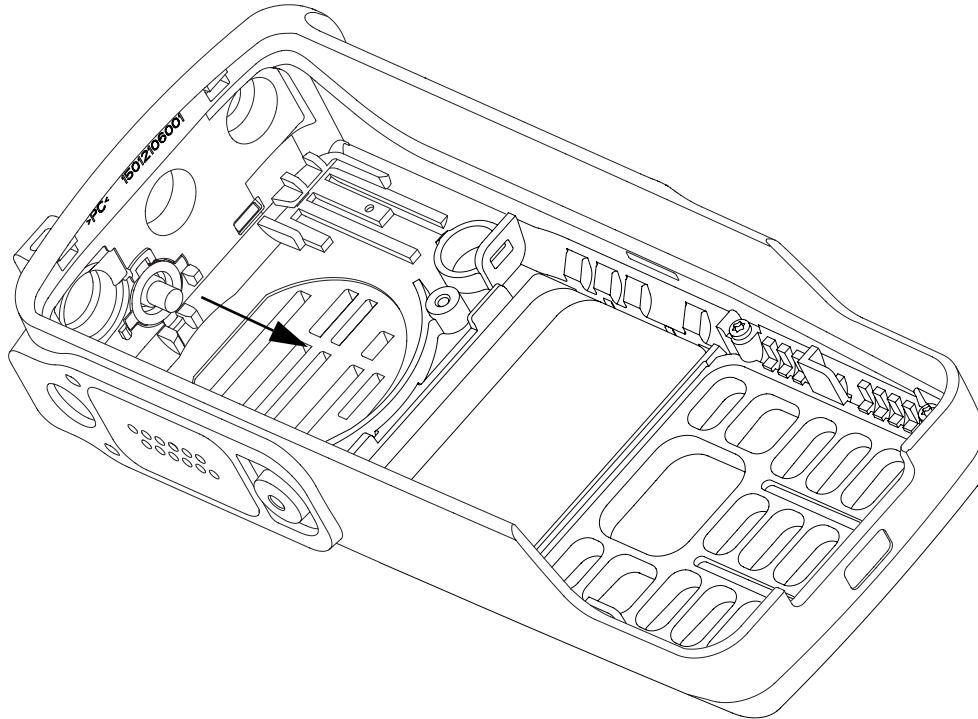

Figure 5-13. Emergency Button disassembly for Full Keypad Model

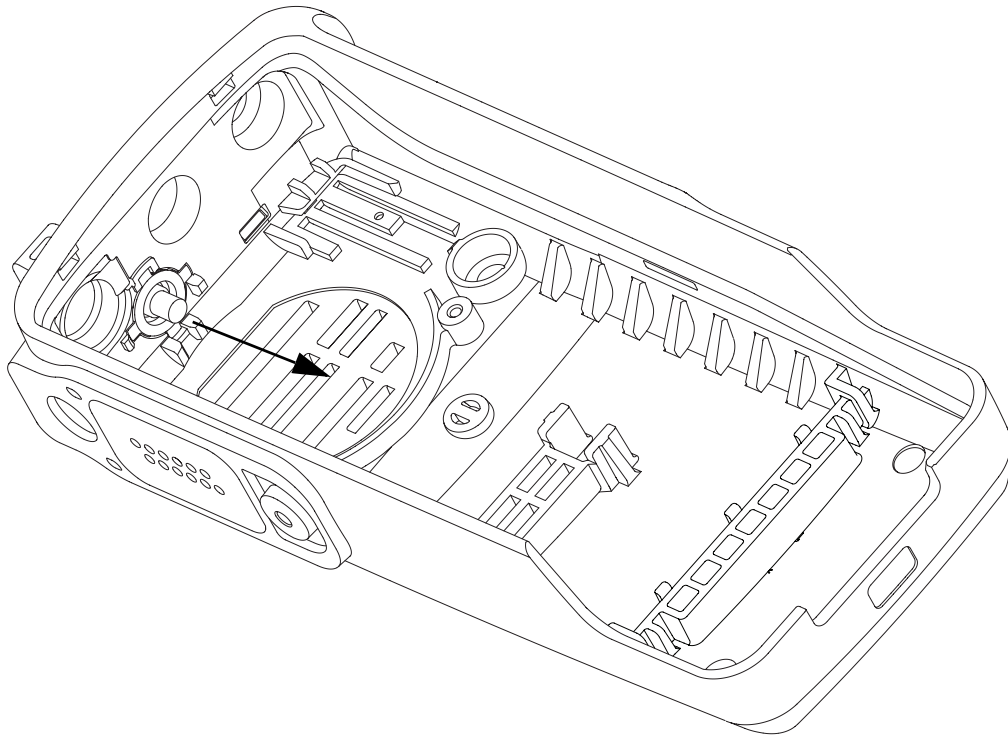

Figure 5-14. Emergency Button disassembly for Non Keypad Model

5.7 Radio Reassembly - Detailed

5.7.1 Emergency Button and Speaker Reassembly

1. Slot in the emergency button in its proper slot.

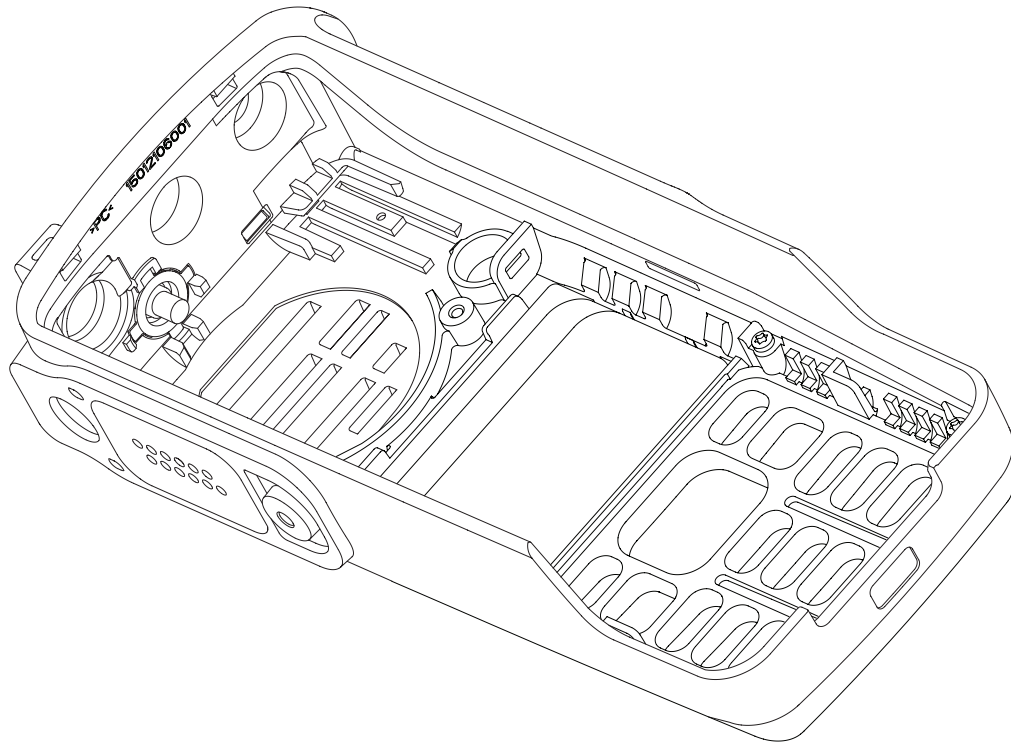

Figure 5-15. Emergency Button reassembly for Full Keypad

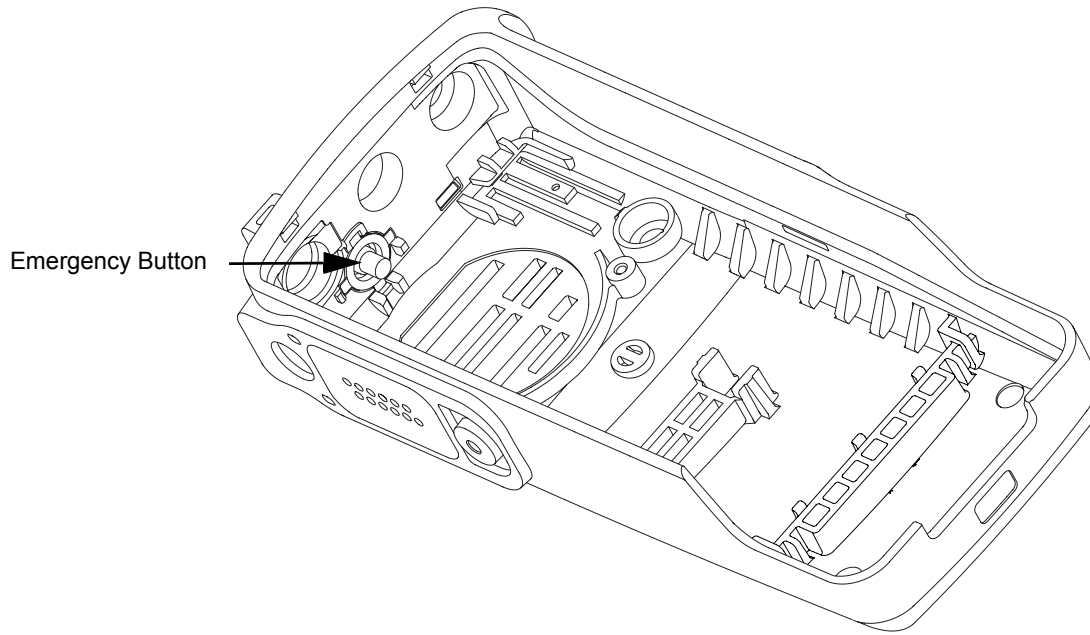

Figure 5-16. Emergency Button reassembly for Non Keypad

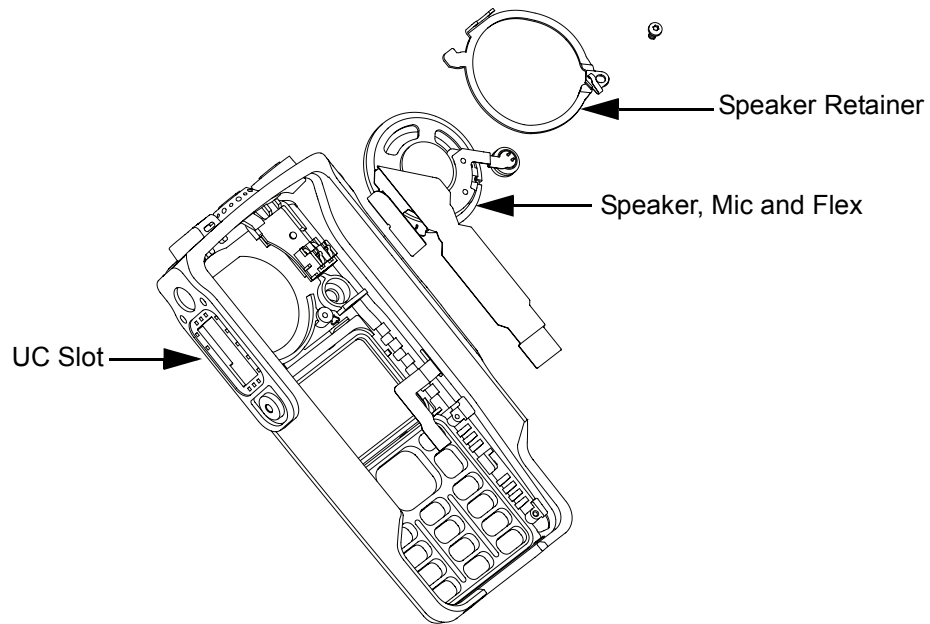

Figure 5-17. Speaker reassembly for Full Keypad

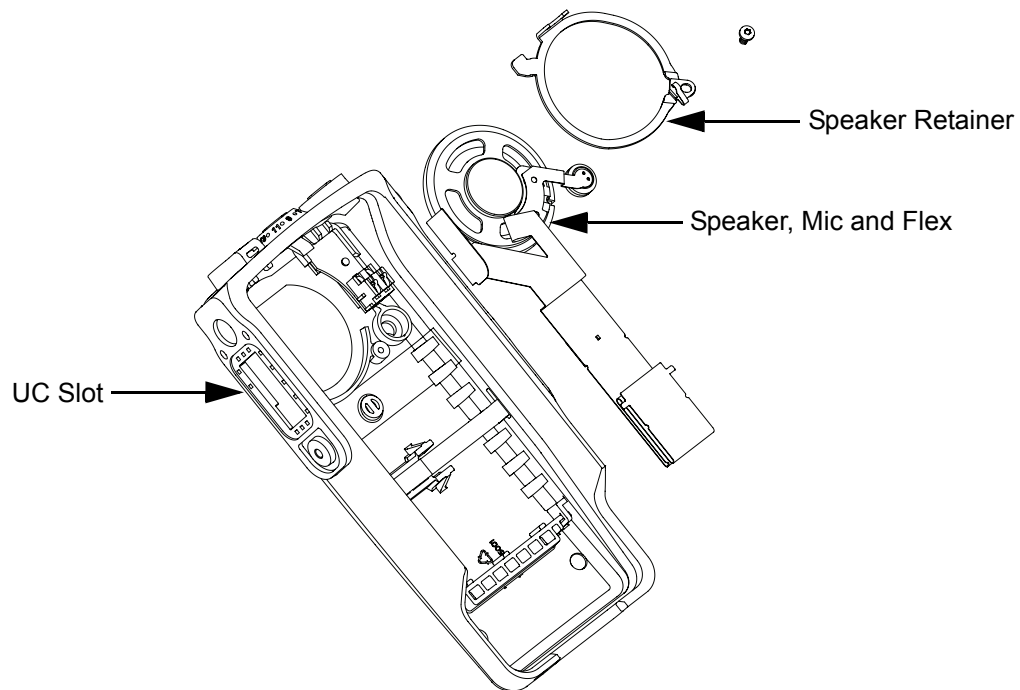

Figure 5-18. Speaker reassembly for Non Keypad

2. Insert the flexes through the speaker retainer so that the speaker retainer is placed directly on the speaker assembly.

NOTE Ensure all the flexes are above the speaker retainer.

3. Slide the universal connector flex into UC slot.
4. Hook in the speaker retainer with speaker assembly at the top left corner of the housing.
5. Affix the appropriate screw on the speaker retainer.
6. Place the mic boot in the appropriate slot.
7. Place a new universal connector escutcheon on the universal connector flex circuit.

5.7.2 Keypad, Display and Keypad Board Reassembly

1. Place the LCD and keypad followed by the keypad board and keypad retainer in the housing.
2. Reconnect the speaker flex, LCD flex and PTT flex to the keypad board and keypad retainer.
3. Slide the keypad retainer in to the latch.
4. Use a TORX screwdriver with a T6 head to affix the screws.

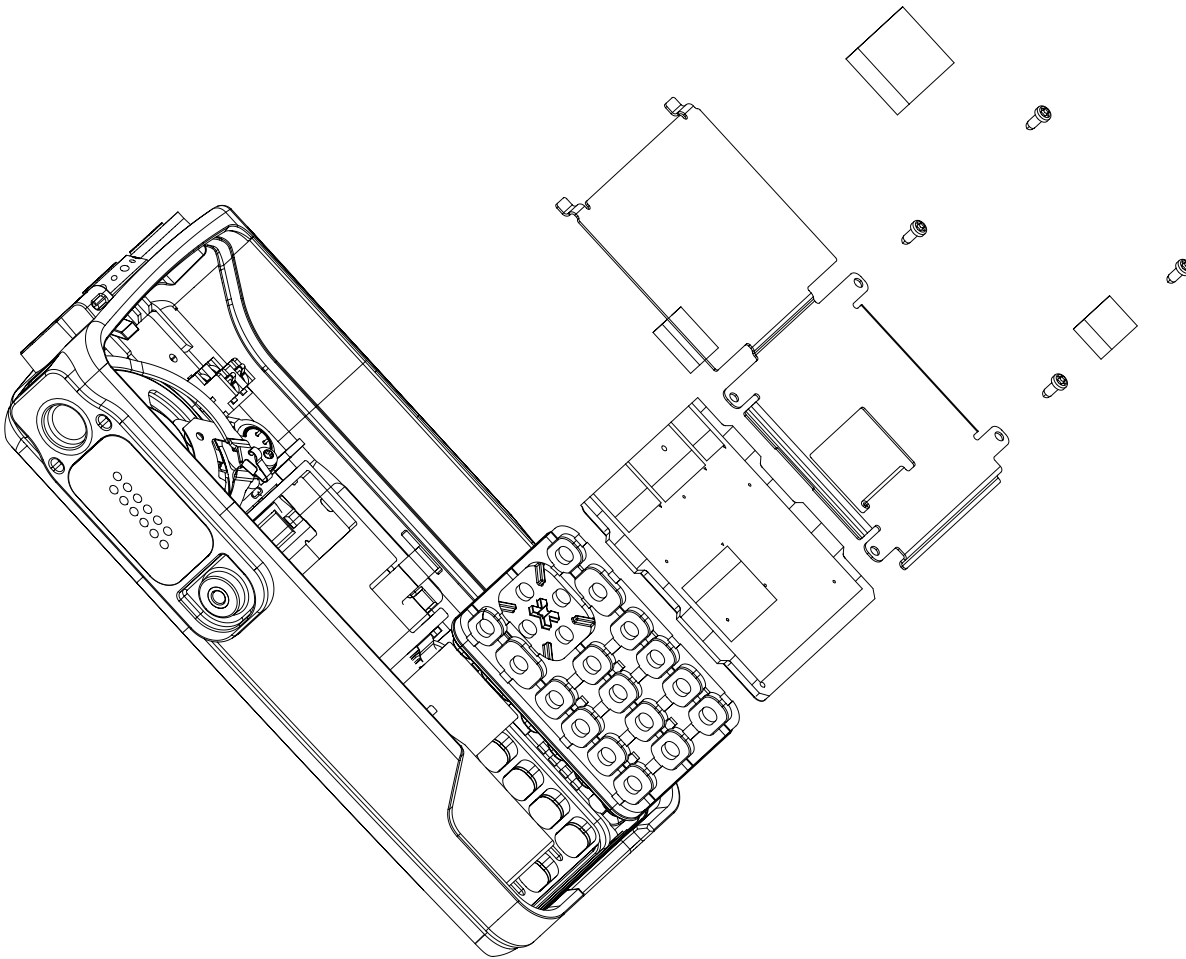

Figure 5-19. Keypad, Display, and Keypad Board reassembly for Full Keypad

5.7.3 Chassis Reassembly

O-ring reassembly:

- i. Ensure that the main O-ring is not twisted and untangle it to its actual form if needed before performing reassembly.
- ii. Insert **D** into the bottom two notches on the chassis.
- iii. Fit **C** around the bottom two corners of the chassis.
- iv. Insert **B1** to **B4** following the sequence as shown in Figure 5-23 on page 26.
- v. Secure **A** into the top 2 notches of the chassis.
- vi. Replace the battery contact seal.

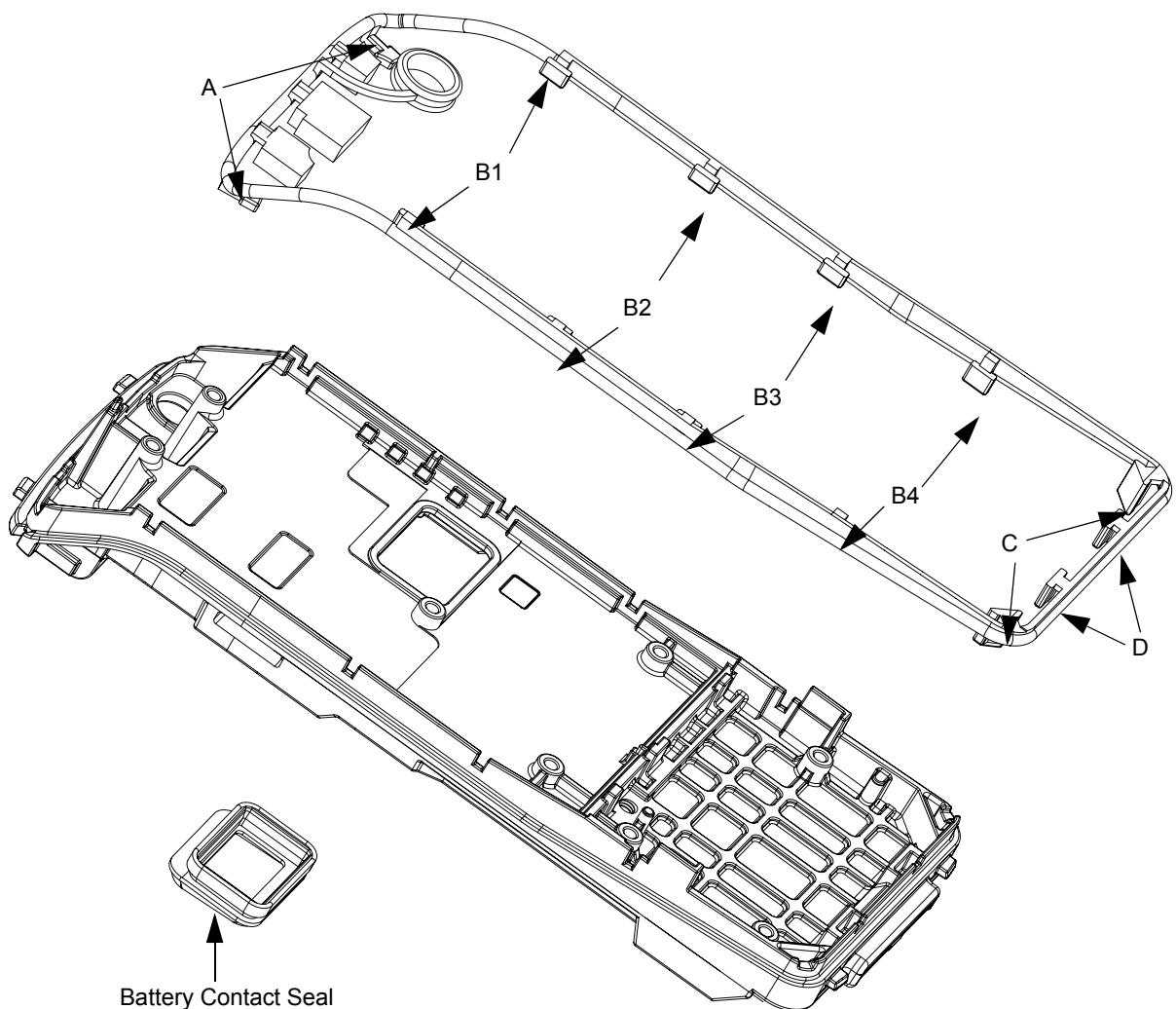

Figure 5-20. O-ring reassembly.

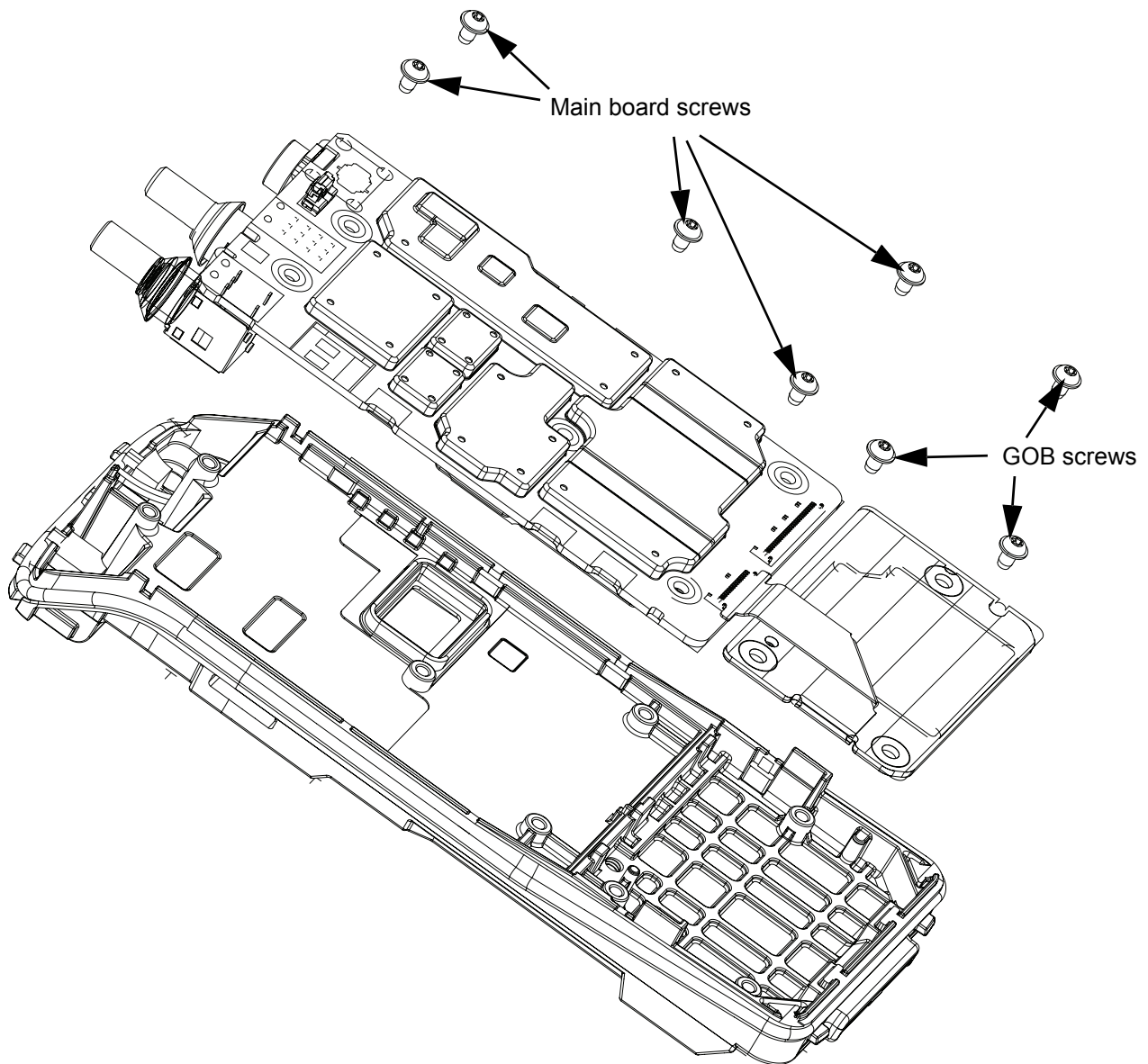

Figure 5-21. Chassis reassembly

1. Place the main board onto the chassis.
2. Tighten the main board screws in the sequence shown in Figure 5-16.
3. Place the GOB on the chassis.

4. Tighten the GOB screws following the sequence shown in Figure 5-17.

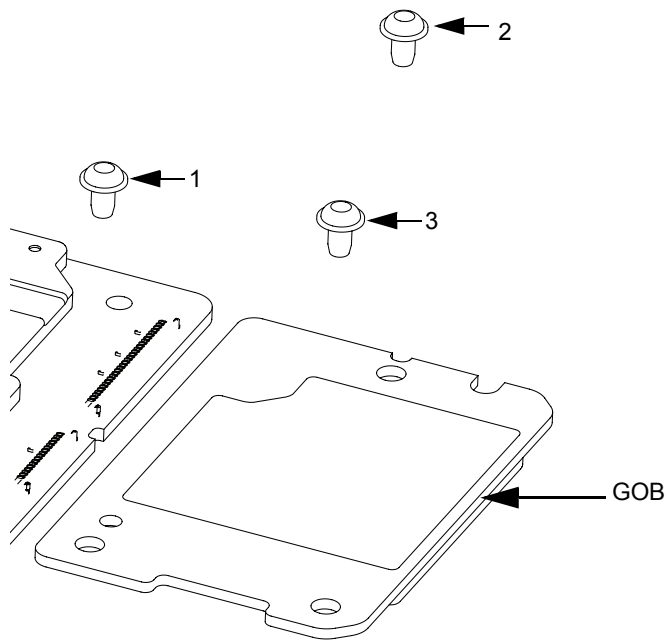

Figure 5-22. GOB reassembly

5. Connect GOB flex to the main board.

6. O-ring reassembly:
- i. Ensure that the main O-ring is not twisted and untangle it to its actual form if needed before performing reassembly.
 - ii. Secure **A** into the top 2 notches of the chassis.
 - iii. Insert **B1** to **B4** following the sequence as shown in Figure 5-20 on page 23.
 - iv. Fit **C** around the bottom two corners of the chassis.
 - v. Insert **D** into the bottom two notches on the chassis

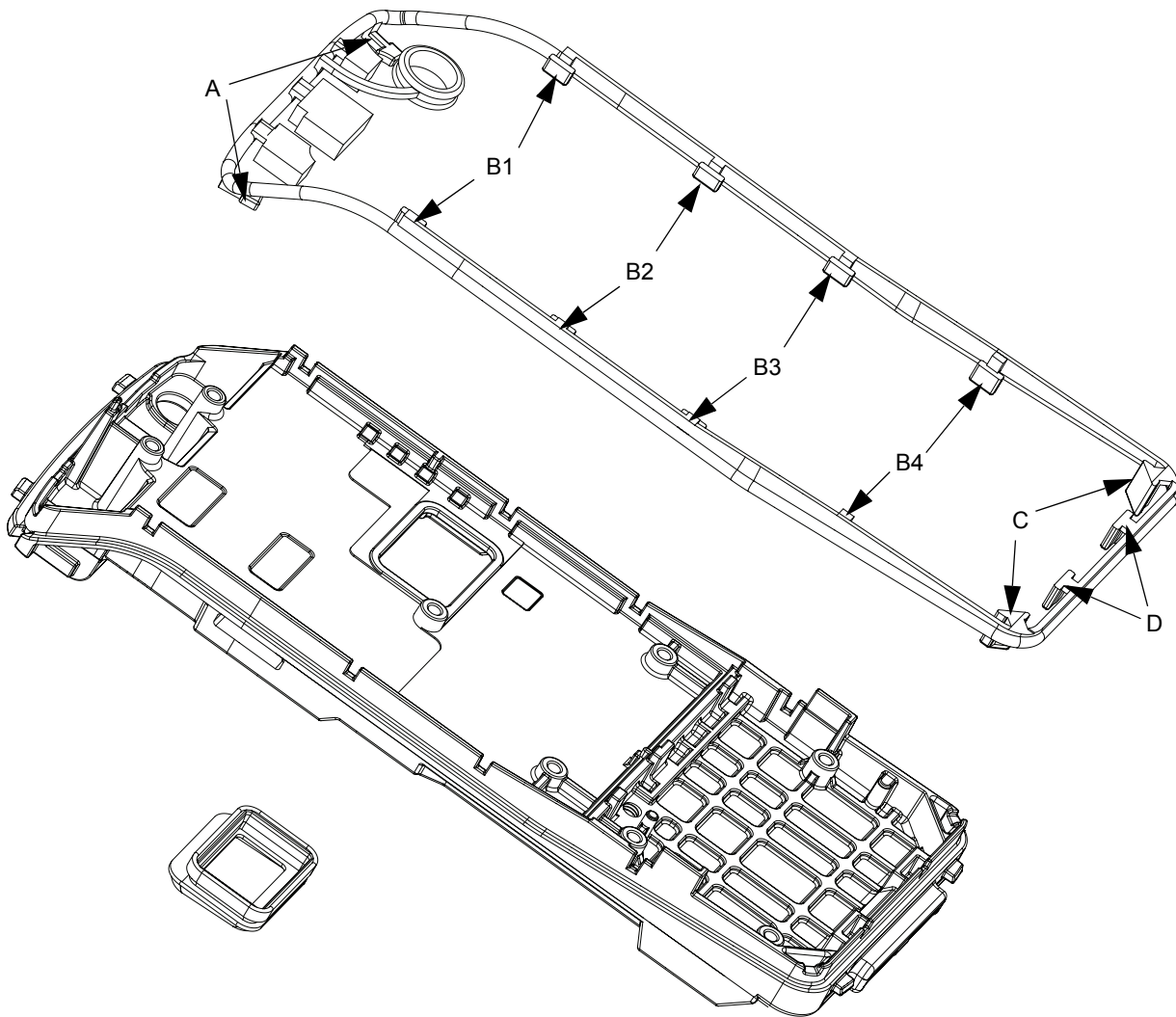

Figure 5-23. O-ring reassembly

5.7.4 Chassis and Front Cover Reassembly

1. Connect the flex to the main board and the keypad board.
2. Insert top chassis tabs into the recesses on front cover and the tabs are fully inserted.
3. Gently push down the chassis into the front cover until it snaps in place.
4. Align the shroud with the top of the front housing and slide it in place.
5. Insert knobs, antenna and battery.

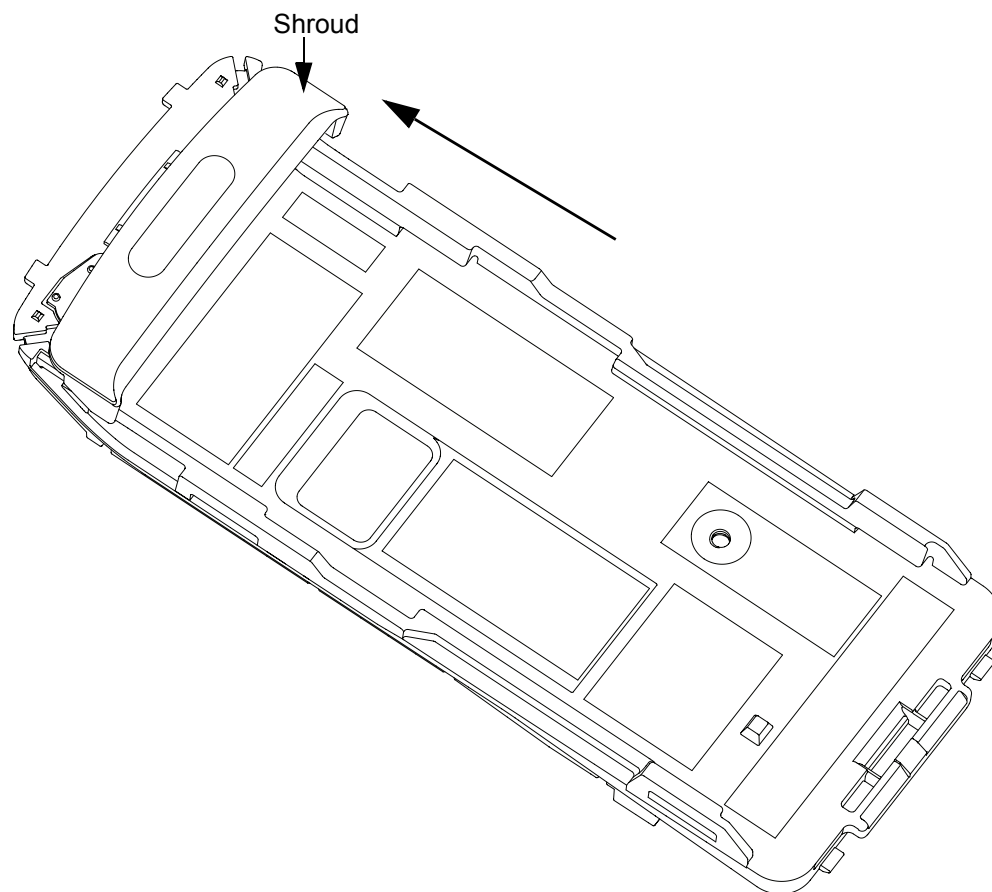

Figure 5-24. Chassis reassembly

5.7.5 Bluetooth Antenna Kit Disassembly/Reassembly

5.7.5.1 Bluetooth Antenna Kit Disassembly

1. Use a T3 Torx screwdriver to unfasten the bluetooth module.

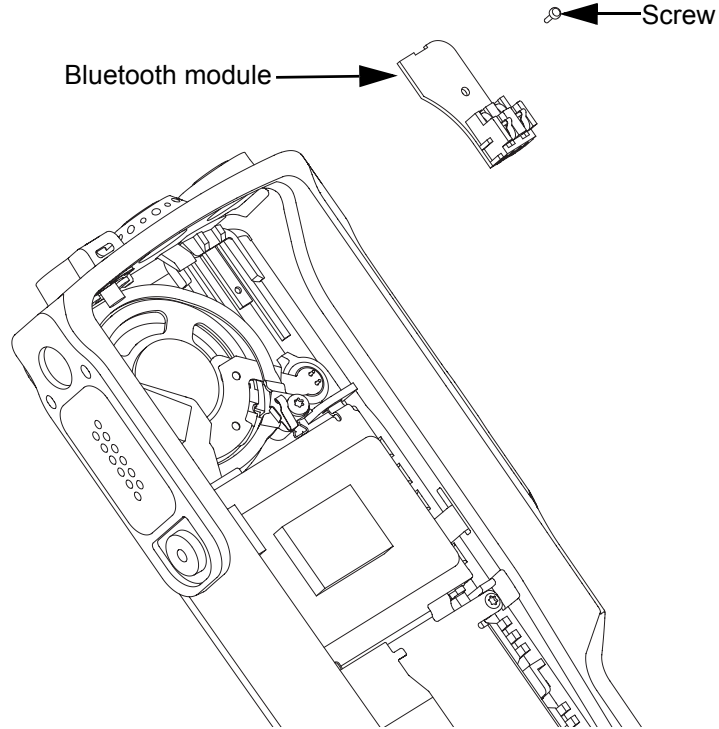

Figure 5-25. Bluetooth removal for Full Keypad

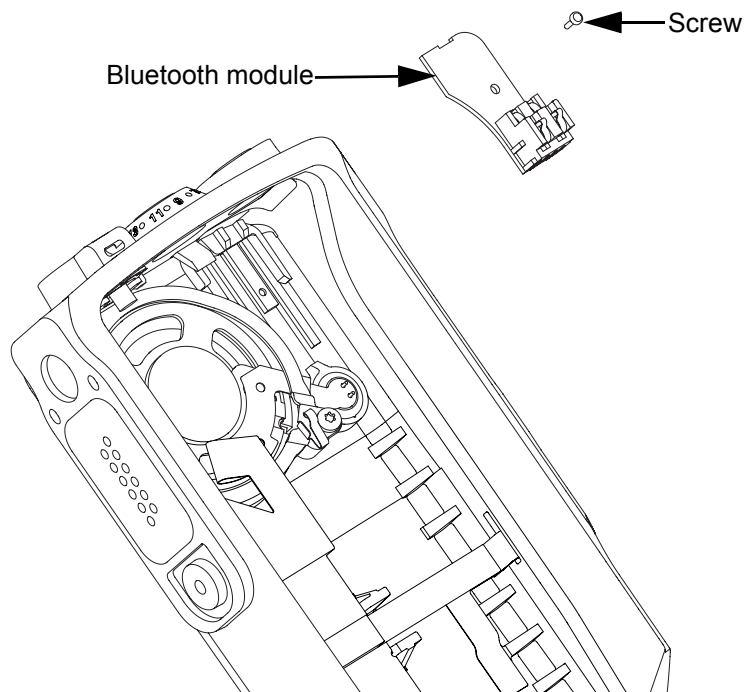

Figure 5-26. Bluetooth removal for Non Keypad

5.7.5.2 Bluetooth Antenna Kit Reassembly

1. Place the Bluetooth module in the housing and fasten with a Torx 3 screwdriver.

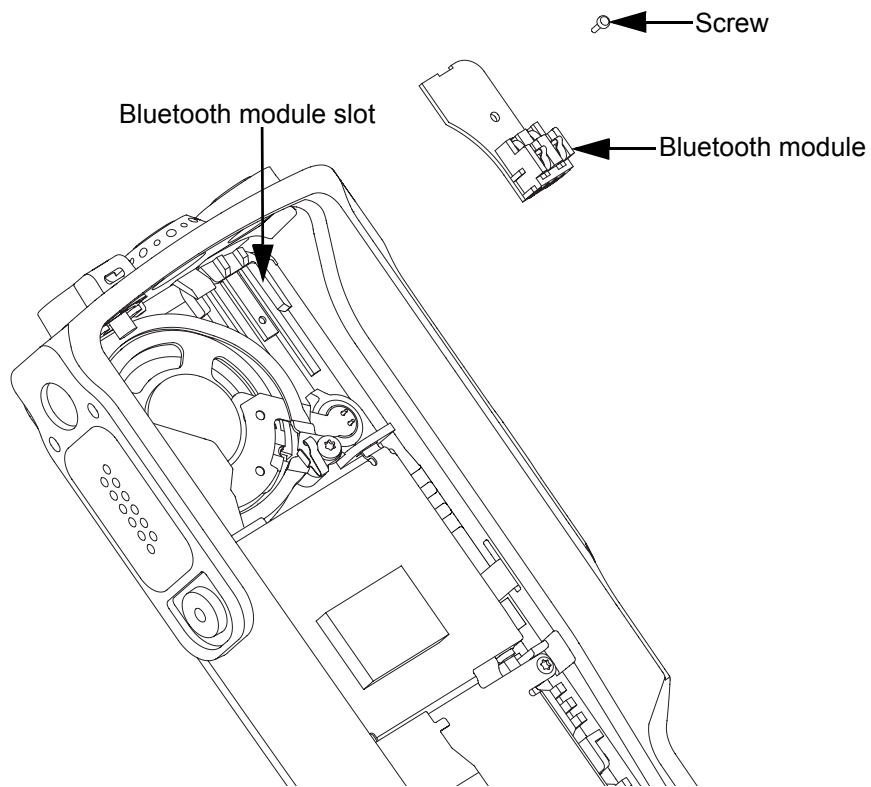

Figure 5-27. Bluetooth reassembly for Full Keypad

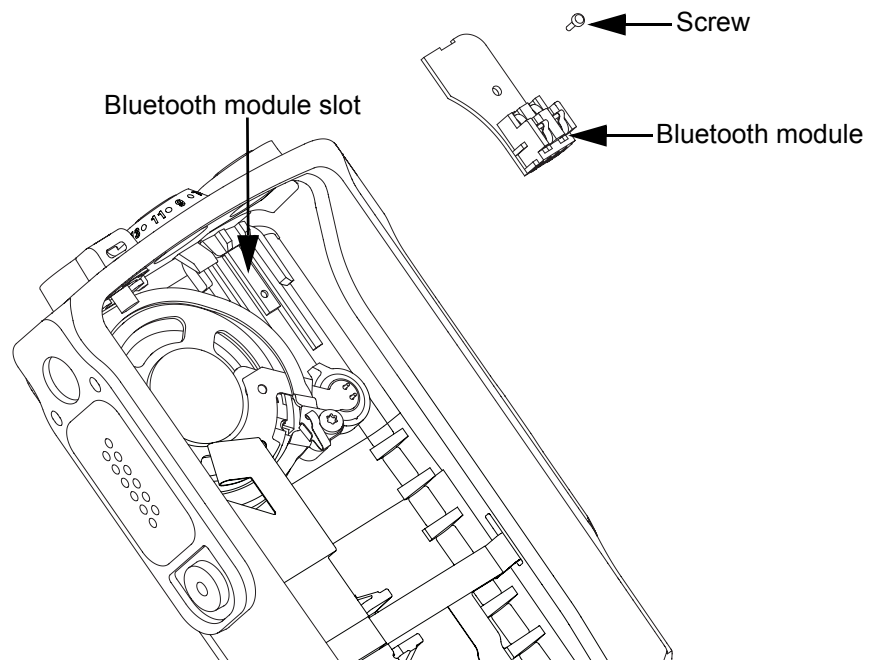
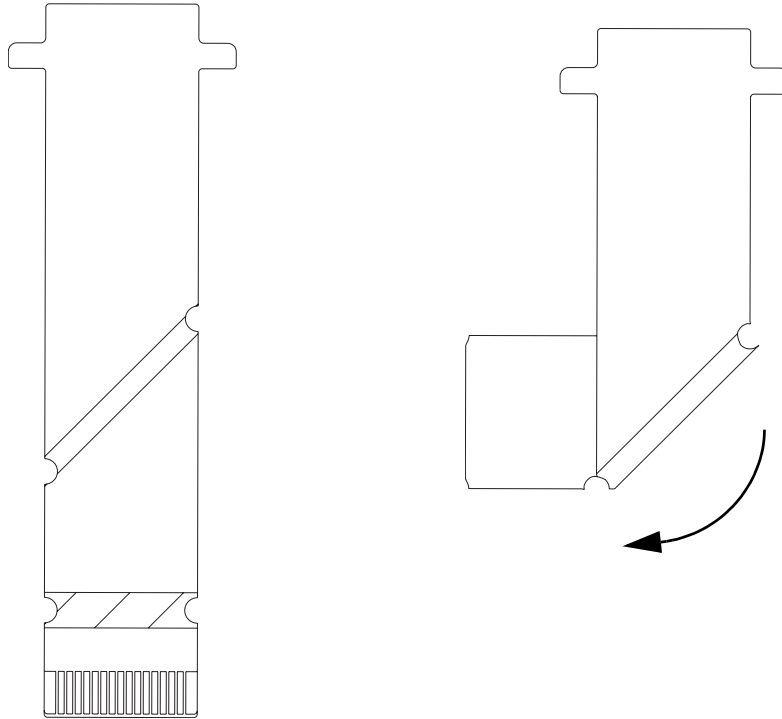

Figure 5-28. Bluetooth reassembly for Non Keypad

5.7.6 GOB Installation

1. Fold the option board flex cable as shown.



2. Peel the adhesive strip off from the spacer supplied and affix the spacer to the bottom side of the option board where marked.

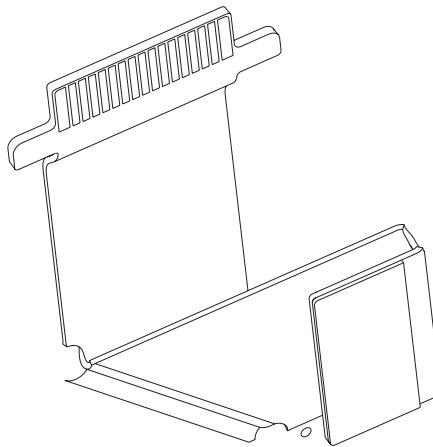

3. Gently lift the connector flap of the option board and connect the option board flex cable. Gently close the flap.

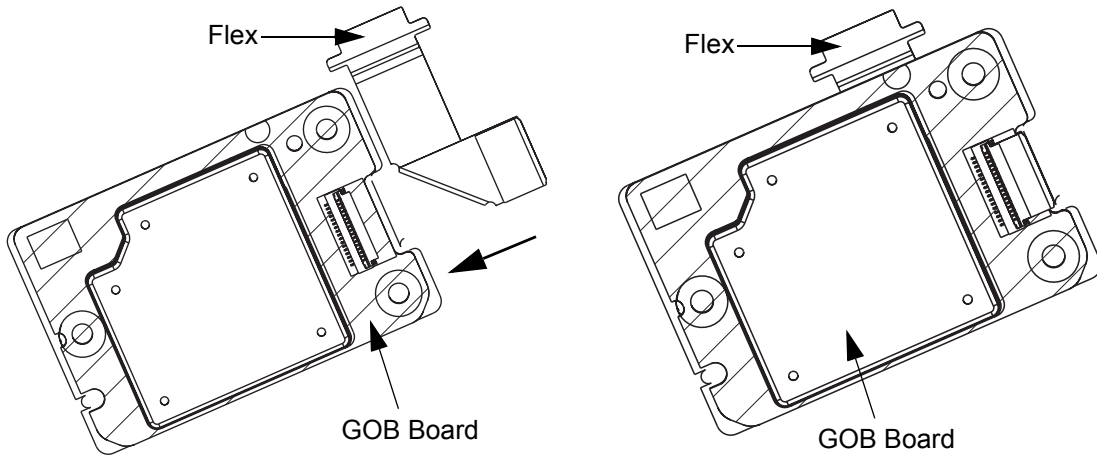

4. Insert the option board with the motherboard into the chassis as shown below.

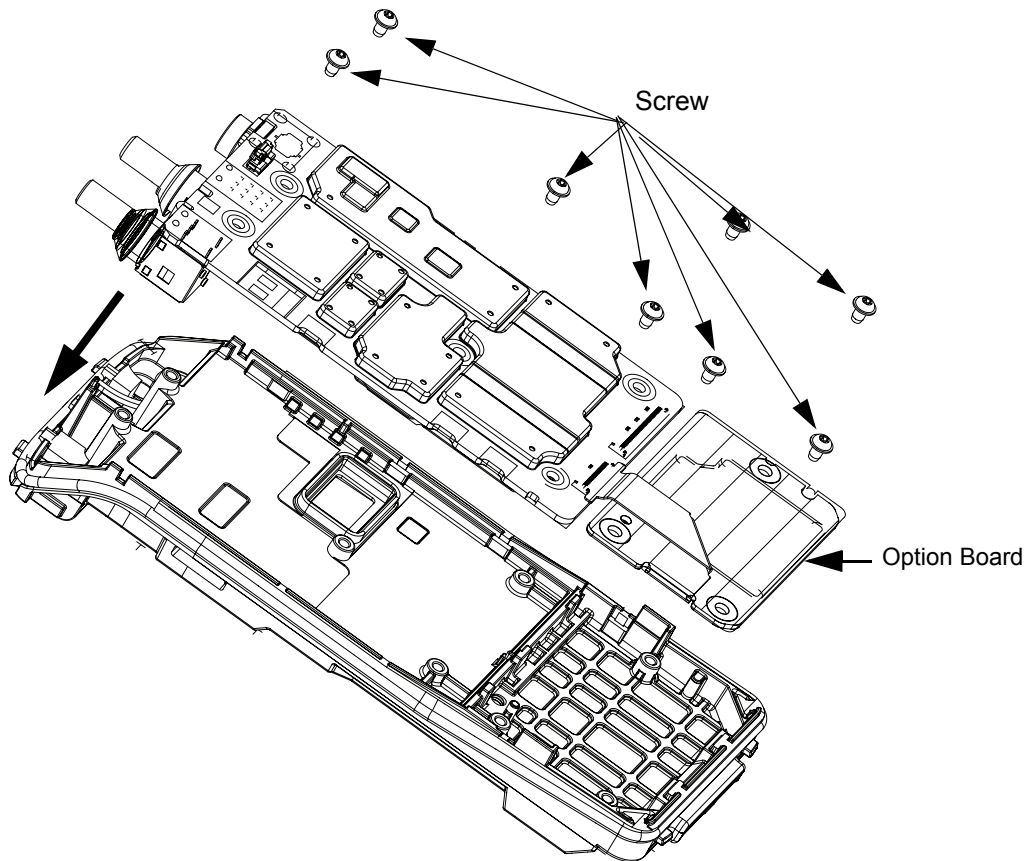

5.8 Ensuring Radio Immersibility

This section discusses radio immersibility concerns, tests, and disassembly and reassembly of the series radios.

5.8.1 Servicing

The series radios shipped from the Motorola factory have passed vacuum testing and should be capable of restoring the watertight integrity of the radio.

 Caution	<p>It is strongly recommended that the maintenance of the radio be deferred to qualified service personnel and service shops. This is of paramount importance as irreparable damage to the radio can result from service by unauthorized persons. If disassembly is necessary, unauthorized attempts to repair the radio may void any existing warranties or extended performance agreements with Motorola. It is also recommended that immersibility be checked annually by qualified service personnel/workshop that is authorized by Motorola.</p>
---	---

5.8.2 Accidental Immersion

If the radio is accidentally dropped in water, shake the radio to remove the excess water from the speaker grille and microphone port area before operating; otherwise, the sound may be distorted until the water has evaporated, or is dislodged from these areas.

5.8.3 Specialized Test Equipment

This section summarizes the specialized test equipment necessary for testing the integrity of the series radios.

To ensure that the radio is truly a watertight unit, special testing, test procedures, and specialized test equipment are required. The special testing involves a vacuum check of the radio and pressure testing (troubleshooting) for water leaks if the vacuum check fails. The specialized test equipment/instrument (Table 2-2 on page 2-2) is authorized by Motorola and needed to perform the vacuum check and pressure testing, if required. Any equipment/tools/instruments not mentioned in the table must not be used to perform these test.

5.8.4 Vacuum Pump Kit NLN9839

The vacuum pump kit includes a vacuum pump with gauge, and a vacuum hose. A connector fitting (part number 5871134M01) and fitting seal (part number 3271133M01) pump connector, which must be ordered separately, connects the vacuum hose to the radio's chassis.

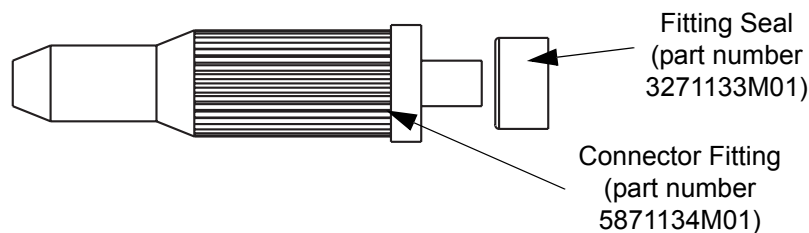

Figure 5-29. Connector Fitting - Fitting Seal Pump Connector

5.8.5 Pressure Pump Kit NTN4265

The pressure pump kit includes a pressure pump with gauge, and a pressure hose. As with the vacuum pump kit above, the connector fitting - fitting seal pair connects the pressure hose to the radio's chassis.

5.8.6 Miscellaneous Hardware

Other items needed for testing the immersibility radio include:

- Large water container
- Deionized (DI) water
- A supply of replacement parts: Main seal O-ring, Battery Contact Seal, Breathing Vent Label and Breathing Vent Membrane.

5.8.7 Vacuum Test

The vacuum test uses a vacuum pump and gauge. The pump creates a vacuum condition inside the radio, and the gauge monitors the radio for a stable vacuum reading; that is, checking for a properly sealed, watertight unit. Before starting the vacuum test:

- Remove the battery.
- Remove the universal connector dustcover to expose the universal connector.
- Remove the breathing vent label and breathing vent membrane.

To conduct the vacuum test:

1. Attach antenna firmly to the radio.
2. Attach the vacuum hose to the vacuum pump. Check the pump and hose for leaks by blocking off the open end of the hose and operating the pump a few times. The actual reading of the gauge at this point is not important; it is important that the gauge pointer remained steady, indicating no vacuum leaks in the pump.
3. Ensure that the fitting seal is attached to the hose-to-chassis pump connector. Screw the pump connector into the tapped hole in the chassis.



Caution

Please do not bend or over tighten pump connector to the chassis.

4. Attach the open end of the hose to the pointed end of the pump connector.
5. Place the radio on a flat surface with the chassis facing upward.
6. Operate the pump until the gauge indicates 6 in. Hg of vacuum on the radio. Observe the gauge for approximately 1 minute.
 - If the needle falls 0.5 in. Hg or less (one scale interval, for example, from 3 in. Hg to 2.5 in. Hg), then the radio has passed the vacuum test and is approved for immersibility. No additional testing will be required.
 - If the needle falls more than 0.5 in. Hg (one scale interval, for example, from 3 in. Hg to less than 2.5 in. Hg), then the radio has failed the vacuum test and the radio might leak if

immersed. Additional troubleshooting of the radio will be required; complete this procedure, then go to Section 5.8.8 "Pressure Test".

7. Remove the vacuum hose and pump connector from the radio.

5.8.8 Pressure Test

Pressure testing the radio is necessary only if the radio has failed the vacuum test. Do not perform the pressure test until the vacuum test has been completed. Pressure testing involves creating a positive pressure condition inside the radio, immersing the radio in water, and observing the radio for a stream of bubbles (leak). Since all areas of the radio are being checked, observe the entire unit carefully for the possibility of multiple leaks before completing this test.

To conduct the pressure test:

1. Screw the pump connector (with fitting seal) into the tapped hole in the chassis.
2. Attach one end of the pressure hose to the pump connector and the other end to the pressure pump.
3. Attach antenna firmly to the radio.
4. Operate the pump until the gauge reads approximately 1 psig.



Caution

Pressure any greater than 1 psig might push air around the main seal

5. Maintain the pressure at 1 psig and immerse the radio into a water-filled container.
6. Watch for any continuous series of bubbles. A stream of bubbles indicates a sign of leakage.

NOTE Some air entrapment may cause the accumulation of bubbles, especially in the grille area, but the bubbles should not be continuous.



Caution

Please do not bend or over tighten pump connector to the chassis.

7. Note all of the seal areas that show signs of leakage. Pinpoint the problem(s) to one (or more) of the following areas:
 - Front Housing
 - Chassis (Main Seal O-ring)
 - Battery Contact Seal
8. Remove the radio from the water container, and dry the radio thoroughly. Be especially careful to dry the area around the main seal to prevent contamination of the internal

electronics while the unit is open



Caution

Keep the area around the chassis's vacuum port dry by ensuring that there is no water around it.

9. Remove the pump connector from the chassis.
10. Radio after performing Pressure Test must undergo baking process in a temperature chamber for constant temperature soaking at 60°C for 1 hour. This is to ensure no moisture is trapped inside the radio and prevent contamination of the internal electronics after reassembling the radio.

5.8.9 Troubleshooting Leak Areas

Before repairing any leak, first read all of the steps within the applicable section. This will help to eliminate unnecessary disassembly and reassembly of a radio with multiple leaks. Troubleshoot only the faulty seal areas listed in Section 5.8.8 "Pressure Test" on page 5-34, and when multiple leaks exist, in the order listed.

NOTE Before reassembling the radio, always install a new Main seal O-ring, Battery Contact Seal in the defective area.

5.8.9.1 Front Housing

Do one or both of the following:

1. If a leak occurs at the Lens (Display Models only), Universal Connector, chassis/Housing interface, PTT button area of the housing, replace the housing. Refer to Section 5.6 "Radio Disassembly – Detailed" on page 5-6.
 - a. Remove the housing assembly from the radio.
 - b. Discard the housing assembly and main seal O-ring.
 - c. Install a new main seal O-ring around the chassis assembly according to Figure 5-23 on page 26.
 - d. Install a new housing assembly to the radio.
 - e. Inspect the main seal for proper seating.
 - f. Observe carefully to ensure that the main seal O-ring is not pinched between the housing and the chassis interface.
2. If the leak occurs at the control top area, remove the knobs in order to determine the leak location:
 - a. Conduct the Pressure Test.
 - b. Identify the leak location.

5.8.9.2 Chassis (Main Seal O-ring)

To replace the main seal O-ring:

1. Refer to Section 5.6.1 "Front Cover from Chassis Disassembly" on page 5-6, remove the

chassis assembly from the radio.

2. Refer to Section 5.6.2 "Chassis Disassembly" on page 5-10, remove the Main Board from chassis.
3. Remove the main seal O-ring.
4. Inspect the seal area around the chassis for foreign material that might prevent the main seal O-ring from sealing properly.
5. Assemble a new O-ring; discard the old O-ring.
6. For detailed O-ring assembly sequence, refer to clause 2, step i. to step viii. of Section 5.7.3 "Chassis Reassembly" on page 5-23.
7. Reassemble the chassis assembly followed by installing into Front Cover. (Refer to Section 5.7 "Radio Reassembly - Detailed" on page 5-19).
8. Inspect the main seal O-ring for proper seating. Observe carefully to ensure that the main seal O-ring is not pinched between the housing and the chassis.

NOTE When installing the assembled chassis to the Front Cover, ensure the O-ring at the top two corners are not dislodged from the chassis groove.

5.8.9.3 Battery Contact Seal

To replace the Battery Contact Seal:

1. Refer to Section 5.6 "Radio Disassembly – Detailed" on page 5-6 to remove the Battery Contact Seal.
2. Remove the Battery Contact Seal from the Chassis.
3. Inspect the Battery Contact Seal, Chassis and surrounding areas for foreign material that might prevent the Battery Contact Seal from sealing properly.
4. Install a new Battery Contact Seal; discard the old Seal.
5. Replace a new main seal O-ring; discard the old O-ring.
6. Reassemble the chassis assembly followed by installing into Front Cover. (Refer to Section 5.7 "Radio Reassembly - Detailed" on page 5-19).
7. Inspect the main seal O-ring for proper seating. Observe carefully to ensure that the main seal O-ring is not pinched between the housing and the chassis.

IMPORTANT: Both Breathing Vent Label (3371478L01) and Breathing Vent Membrane (3271570L01) need to be replaced after vacuum test, pressure test or water leakage troubleshooting.

5.8.9.4 Breathing Vent Membrane and Breathing Vent Label

To replace the Breathing Vent Membrane and Breathing Vent Label:

1. Remove the Breathing Vent Label that covers the Breathing Vent Membrane from the chassis.
2. Remove the Breathing Vent Membrane.
3. Ensure that the chassis's surface (at the Breathing Vent Label & Breathing Vent Membrane recessed) is clean, no/minimum scratches and free from any adhesive or other foreign materials.
4. Install a new Breathing Vent Membrane, covering the vent port hole, in the small recessed area in the chassis. Ensure that no oily substance come in contact with the seal.
5. Install a new Breathing Vent Label over the Breathing Vent Membrane in the larger recessed area in the chassis. Press down evenly over the label's surface to ensure good adhesion.

5.8.9.5 Battery Maintenance

1. As part of an Annual Battery Maintenance Program or as required (when the battery contacts are dirty or show signs of wear) it is recommended that the Battery's Radio-side and Charger-side contacts are cleaned with DeoxIT®GOLD cleaner/lubricant.
2. DeoxIT®GOLD (Supplier CAIG Labs, P/N G100P) cleaner/lubricant pen has been found to be very effective at cleaning and extending the life of the battery's contacts. DeoxIT®GOLD cleaner/lubricant is available at numerous electronics suppliers (Radio Shack, McMaster Carr, Fry's, etc.) and directly from manufacturer, CAIG Labs, at <http://www.caig.com>.
3. This pen based package is recommended as it provides better access to the recessed contacts of the battery. The pen's tip may need to be modified (trimmed on the sides) to improve penetration into the battery contact slots. Per the manufacturer's instructions, shake the pen until the fluid begins to flow and wipe the battery's contact surface with the felt tip. After cleaning, inspect the contact surfaces for signs of advanced wear.
4. Advanced contact wear is defined as wear through either the contact platings (gold and nickel) to the base metal (copper). Copper exposure is characterized by a distinctive orange-brown metal appearance surrounded by the silvery nickel underplate and gold top coat.
5. In some cases, a magnified (10x minimum) inspection may be required to verify wear through to the base material. Polishing of the gold or nickel surface is common and is not considered a need for replacement. In instances where advanced wear is evident, the battery should be replaced.
6. After cleaning the contact areas of any foreign material, let the lubricant/cleaner dry for 2 minutes. Replace the battery on the radio and test for intermittency by moving the battery relative to the radio as might occur in regular use.

NOTE Regular maintenance (at least annually) of this area is recommended to ensure contamination free interface and to prolong the life of the battery contacts.

5.8.10 Troubleshooting Charts

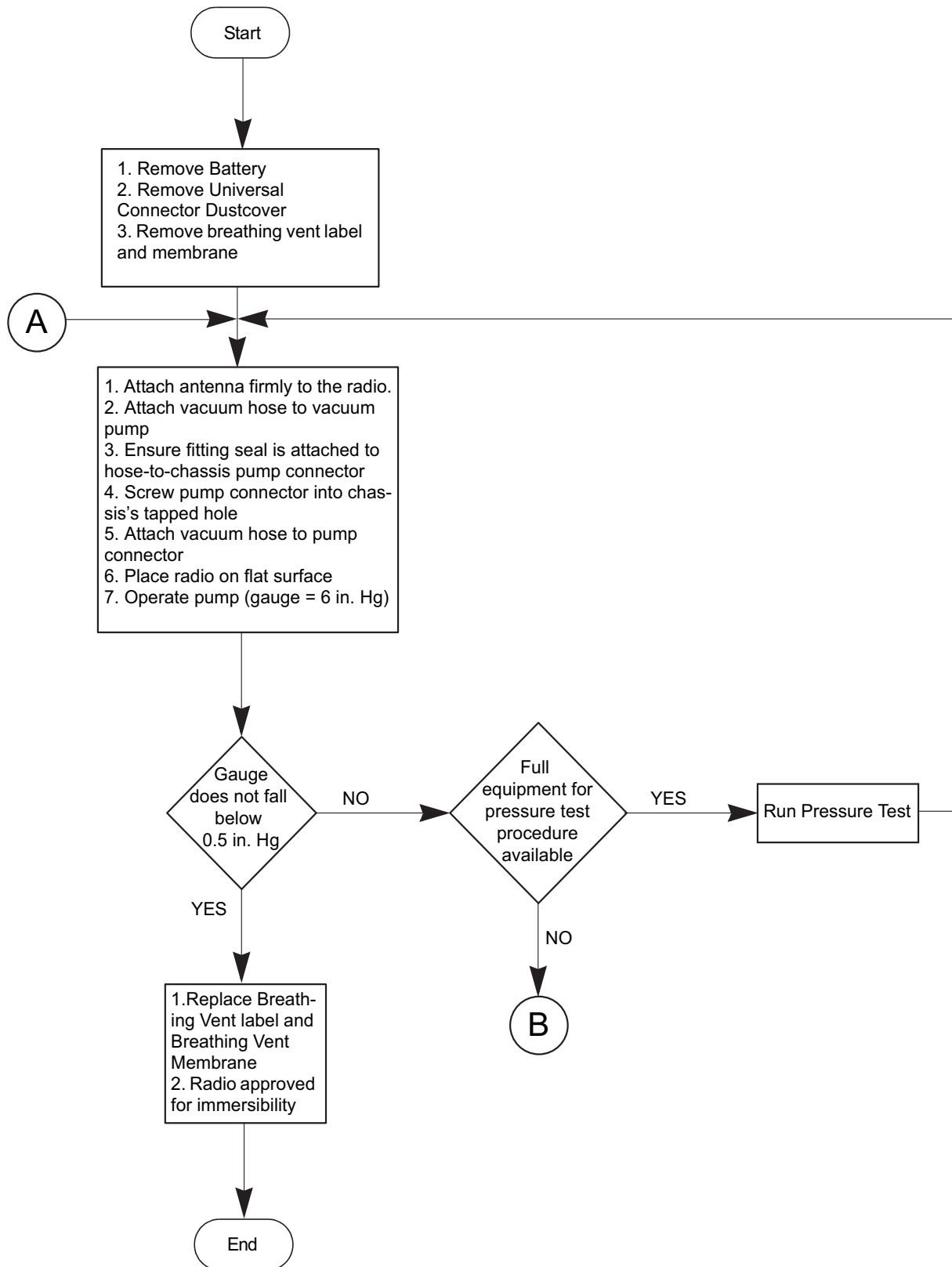

Troubleshooting Flow Chart for Vacuum Test (Sheet 1 of 2)

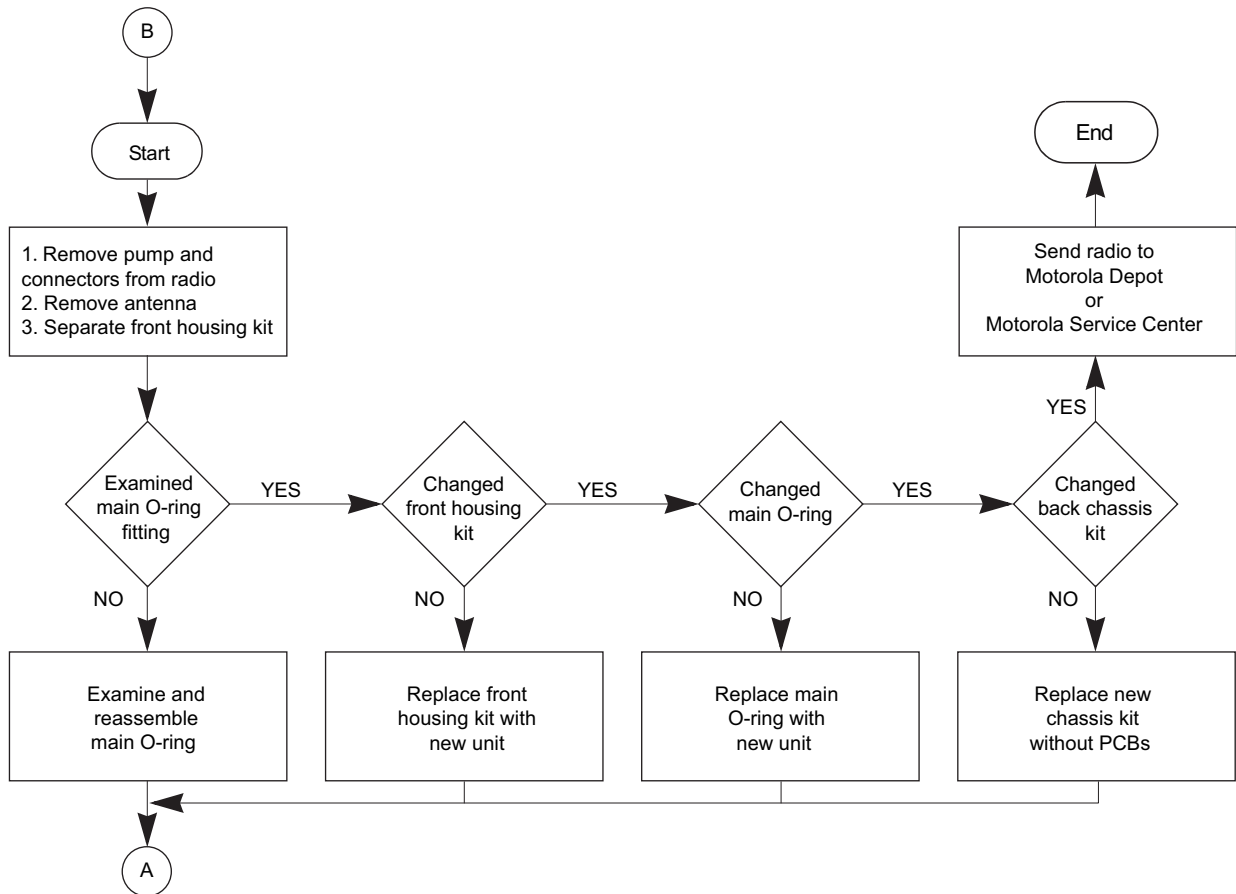

Troubleshooting Flow Chart for Vacuum Test (Sheet 2 of 2)

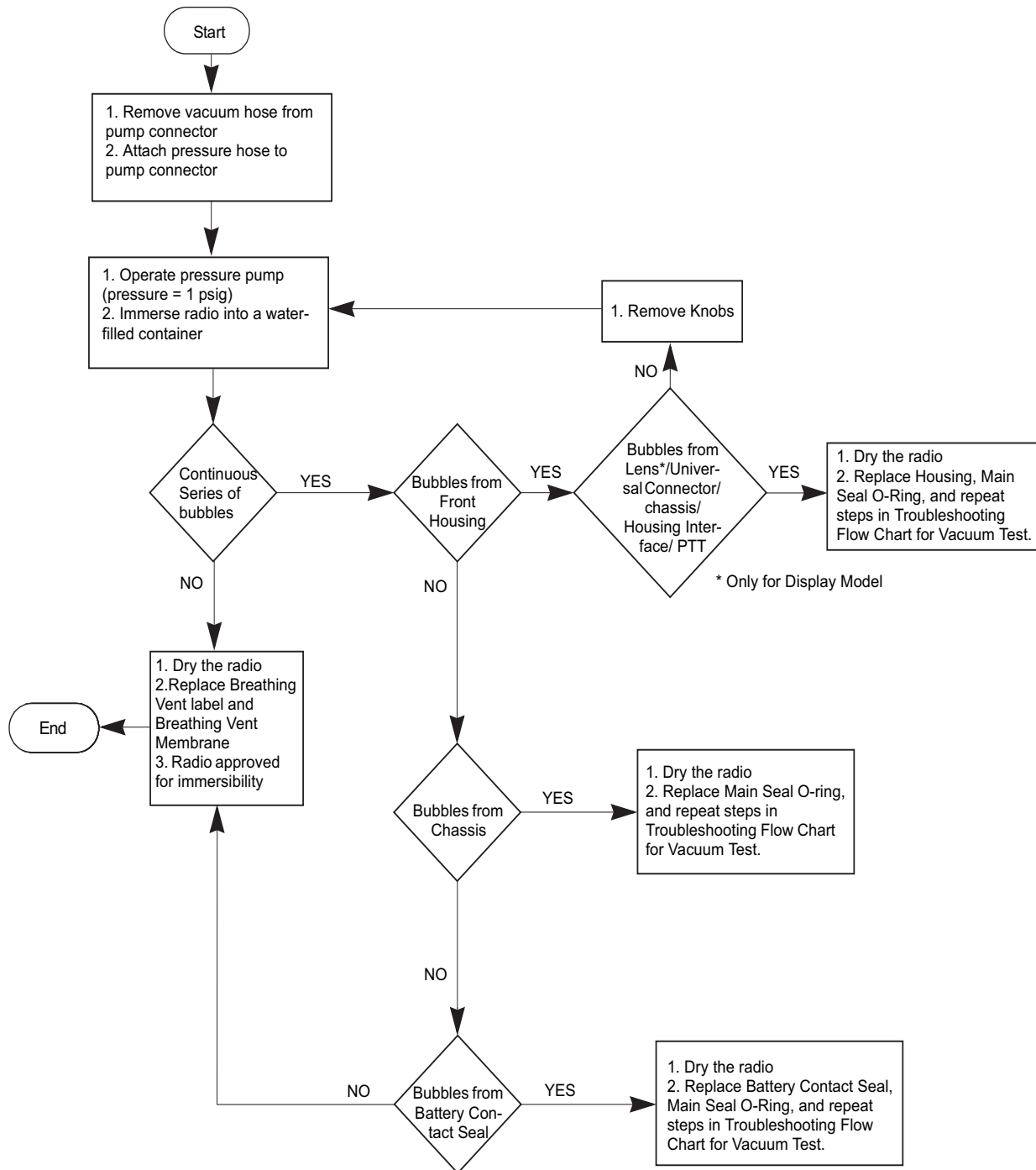

Troubleshooting Flow Chart for Pressure Test & Leakage Areas

5.9 Radio Exploded Mechanical Views and Parts Lists

5.9.1 Full Keypad Model Exploded View and Parts List

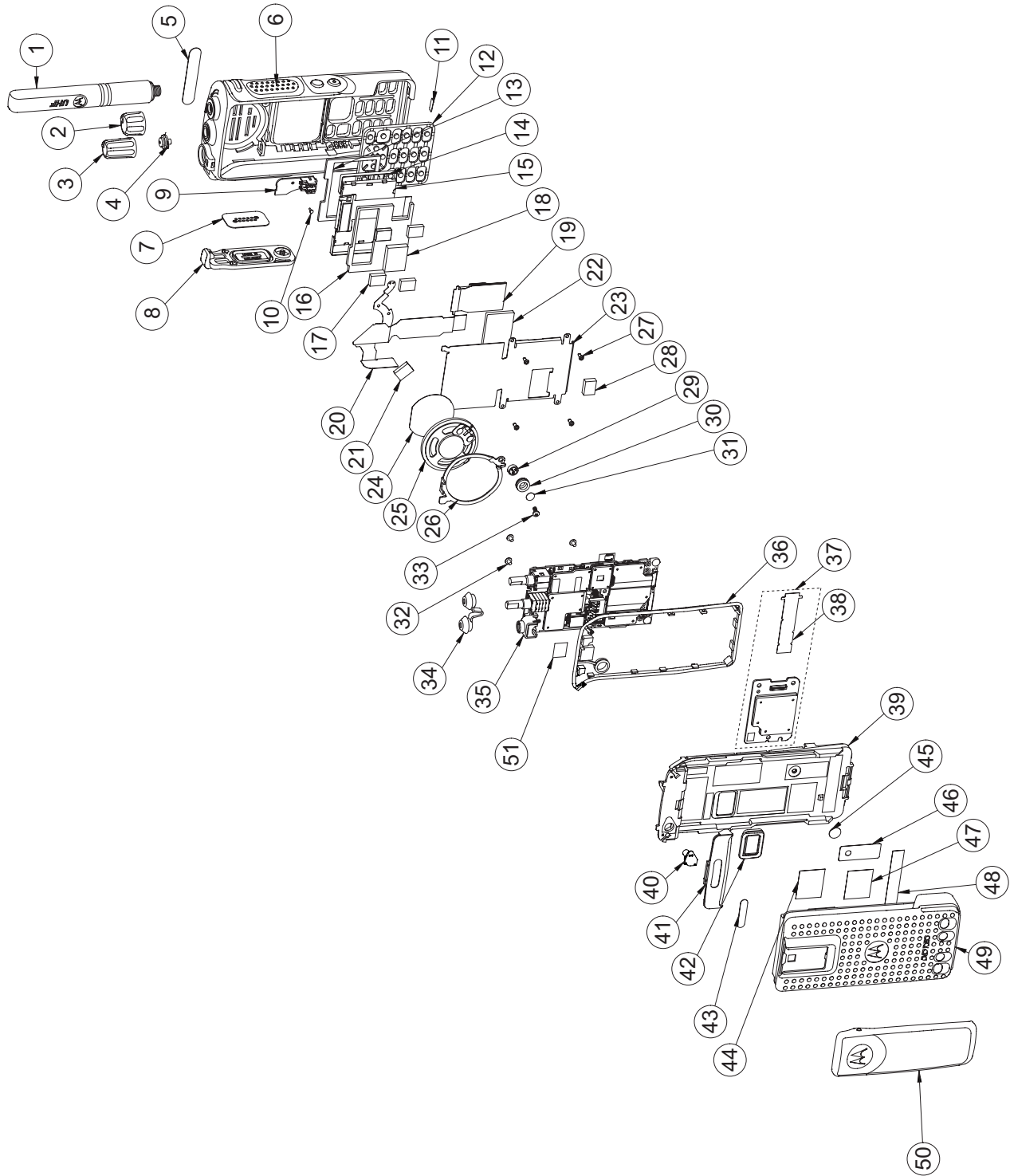

Figure 5-30. Full Keypad Model Exploded View

Table 5-3. Full Keypad Model Exploded View Parts List

Item	Description	Part Number
1	Antenna	See Chapter 7: Accessories
2	Volume Knob	36012005001
3	Frequency Knob	36012004001
4	Emergency Button	38012008001
5	Nameplate, Front	33012037001
6	Front Cover Kit*	See Table 5-6
7	UC Escutcheon	Part of Front Cover kit
8	Dust Cover Assembly	15012157001
9	Bluetooth / GPS Antenna	85012045001
10	Screw, Shoulder, M1.2 X 3.2 MM	0371160D01
11	Label, Agency Indicator	54012222001
12	Full Keypad	See Table 5-6
13	Front Dampener, Color Display	75012070001
14	Color Display Padding	75012137001
15	Color Display Module	72012010001
16	Back Dampener, Color Display	75012069001
17	Conductive Pad (Small)	75012148001
18	Conductive Pad (Big)	75012143001
19	Keypad to Mainboard Flex	84012214005
20	UC to Keypad Flex	Part of Front Cover kit
21	TX Shield Poron	75012117001
22	Keypad Stiffener	75012094001
23	Keypad-LCD Retainer	42012029001
24	Mesh, Speaker	35012040001
25	Speaker, Electromagnetic, 36mm Dia	50012013001
26	Retainer Assembly, Speaker	0104045J57
27	Keypad Retainer Screw	0378212A02
28	Conductive Poron	3916290H01

Table 5-3. Full Keypad Model Exploded View Parts List

Item	Description	Part Number
29	Microphone, EMI, Electret Condenser	50012012001
30	Boot, Microphone	32012099001
31	Mic Membrane with Stiffener	3578241A02
32	Screw, Main Board	3012034001
33	Screw, Thread Forming	0386434Z02
34	Seal, Top Control	32012089001
35	Back Cover Kit Assembly**	See Table 5-6
36	Main O-Ring	32012097001
37	Option Board Kit	PMLN5718AS
38	GOB to Mainboard Flex	84012217003
39	Chassis	Part of Back Cover kit
40	Rubber Plug	38012017001
41	Housing, Shroud	15012092001
42	Battery Contact Seal	32012096001
43	Nameplate	See Table 5-6
44	Warning Label	3371496L01
45	Gasket	3286058L01
46	Gore Label	5478220A01
47	RF Label	54012133001
48	Chassis Label	See Table 5-6
49	Battery	See Chapter 7: Accessories
50	Belt Clip	See Table 5-6
51	Pad, Thermal	7515526H01

NOTE: * Comprises of 4,5,7,9,10,12,13,14,15,16,17,18,19,20,21,22,23,24,25,26,27,28,29,30,31 and 33

** Comprise of 32,34,35,36,37,39,40,41,42,43,44 and 47

5.9.2 Limited Keypad Model Exploded View and Parts List

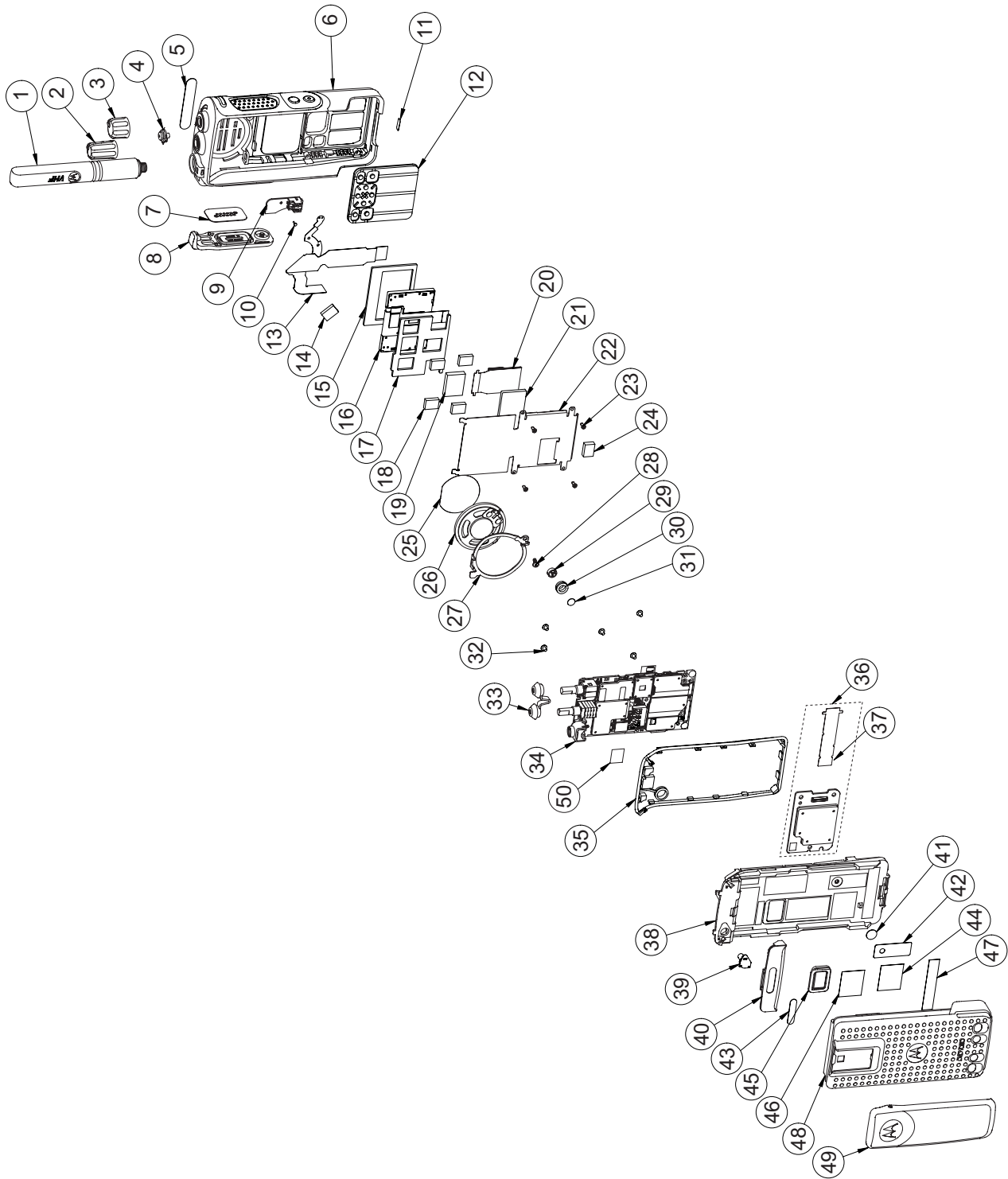

Table 5-4. Limited Keypad Model Exploded View Parts List

Item	Description	Part Number
1	Antenna	See Chapter 7: Accessories
2	Knob, Frequency	36012004001
3	Knob, Volume	36012005001
4	Emergency Button	38012008001
5	Nameplate Front	33012037001
6	Front Cover Kit*	See Table 5-6
7	UC Escutcheon	13012035001
8	Dust Cover Assembly	15012157001
9	BlueTooth/GPS Antenna	85012045001
10	Screw, Shoulder, M1.2 X 3.2 MM	0371160D01
11	Label, Agency Indicator	54012222001
12	Limited Keypad	75012063001
13	UC to Keypad Flex	84012269002
14	TX Shield Poron	75012117001
15	Front Dampener, Display	75012066001
16	Display Module	72012007001
17	Back Dampener, Display	75012065001
18	Conductive Pad (Small)	75012148001
19	Conductive Pad (Big)	75012143001
20	Keypad to Mainboard Flex	84012214005
21	Keypad Stiffener	75012094001
22	Keypad-LCD Retainer	42012029001
23	Keypad Retainer Screw	0378212A02
24	Conductive Poron	3916290H01
25	Mesh, Speaker	35012040001
26	Speaker, Electromagnetic, 36mm Dia	50012013001
27	Retainer Assembly, Speaker	0104045J57
28	Keypad Retainer Screw	0378212A02
29	Microphone, EMI, Electret Condenser	50012012001
30	Boot, Microphone	32012099001

Table 5-4. Limited Keyparts/Notes/Exploded View Parts List

Item	Description	Part Number
31	Mic Membrane with Stiffener	3578241A02
32	Screw, Main Board	3012034001
33	Seal, Top Control	32012089001
34	Back Cover Kit Assembly**	See Table 5-6
35	Main O-Ring	32012097001
36	Option Board Kit	PMLN5718AS
37	GOB to Mainboard Flex	84012217003
38	Chassis	27012010001
39	Rubber Plug	38012017001
40	Housing, Shroud	15012092001
41	Gasket	3286058L01
42	Gore Label	5478220A01
43	Nameplate	See Table 5-6
44	RF Label	54012133001
45	Battery Contact Seal	32012096001
46	Warning Label	3371496L01
47	Label Chassis	See Table 5-6
48	Battery	See Chapter 7: Accessories
49	Belt Clip	See Table 5-6
50	Pad, Thermal	7515526H01

NOTE: * Comprises of 4,5,7,9,10,12,13,14,15,16,17,18,19,20,21,22,23,24,25,26,27,28,29,30 and 31

** Comprise of 32,33,35,36,37,38,40,43,44,45 and 46

5.9.3 Non Keypad Model Exploded View and Parts List

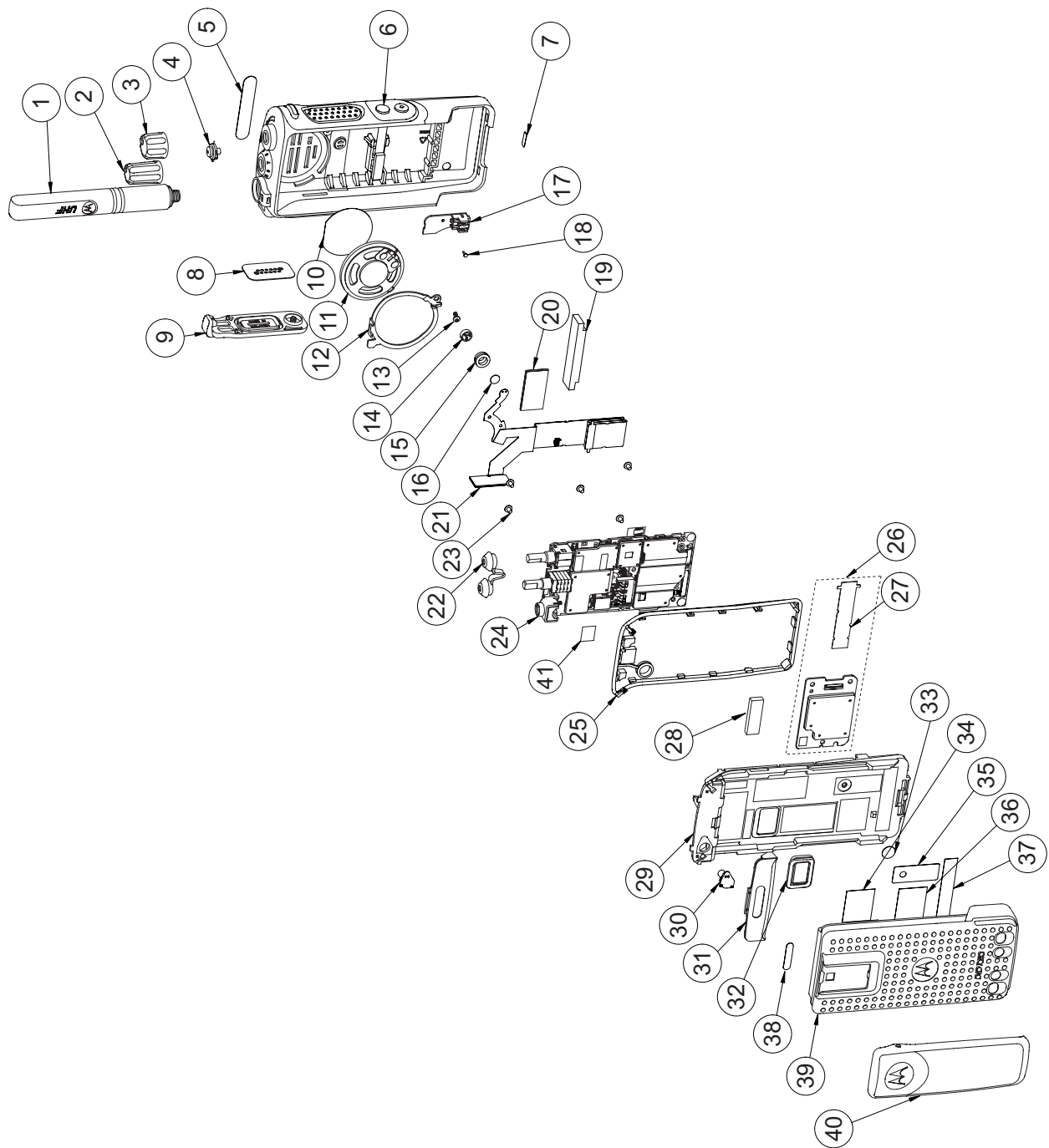

Table 5-5. Non-Display Model Exploded View Parts List

Item	Description	Part Number
1	Antenna	See Chapter 7: Accessories
2	Knob, Frequency	36012004001
3	Knob, Volume	36012005001
4	Emergency Button	38012008001
5	Nameplate Front	33012037001
6	Front Cover Kit*	See Table 5-6
7	Label, Agency Indicator	54012222001
8	UC Escutcheon	Part of Front Cover kit
9	Dust Cover Assembly	15012157001
10	Mesh, Speaker	35012040001
11	Speaker, Electromagnetic, 36mm Dia	50012013001
12	Retainer Assembly, Speaker	0104045J57
13	Keypad Retainer Screw	0378212A02
14	Microphone, EMI, Electret Condenser	50012012001
15	Boot, Microphone	32012099001
16	Mic Membrane with Stiffener	3578241A02
17	BlueTooth/GPS Antenna	85012045001
18	Screw, Shoulder, M1.2 X 3.2 MM	0371160D01
19	Plain Front Housing Poron	75012131001
20	Plain UC Flex Poron	75012103001
21	UC to Keypad Flex	Part of Front Cover kit
22	Seal, Top Control	32012089001
23	Screw, Main Board	3012034001
24	Back Cover Kit Assembly**	See Table 5-6
25	Main O-Ring	32012097001
26	Option Board Kit	PMLN5718AS
27	GOB to Mainboard Flex	84012217003
28	Plain PTT Flex Poron	75012102001
29	Chassis	Part of Back Cover kit
30	Rubber Plug	38012017001
31	Housing, Shroud	15012092001

Table 5-5. Non-Display Model Exploded View Parts List

Item	Description	Part Number
32	Battery Contact Seal	32012096001
33	Gasket	3286058L01
34	Warning Label	3371496L01
35	Gore Label	5478220A01
36	RF Label	54012133001
37	Label Chassis	See Table 5-6
38	Nameplate	See Table 5-6
39	Battery	See Chapter 7: Accessories
40	Belt Clip	See Table 5-6
41	Pad, Thermal	7515526H01

NOTE:* Comprises of 4,5,8,10,11,12,13,14,15,16,17,18,19,20,21 and 28

** Comprise of 22,23,24,25,26,29,30,31,32,34,36 and 38

Table 5-6. Additional Part List information

Item	Description	Part Number
Front Cover Kit	Front Kit, English (FKP)	PMLN5961A
	FRONT COVER KIT ENGLISH BT FKP	PMLN6116A
	Front Kit, Cyrillic (FKP)	PMLN5689A
	FRONT COVER KIT CYRILLIC BT FKP	PMLN6113A
	Front Kit, Arabic (FKP)	PMLN5963A
	FRONT COVER KIT ARABIC BT FKP	PMLN6114A
	Front Cover Kit LKP	PMLN5690A
	FRONT COVER KIT BT LKP	PMLN6112A
	Front Cover Kit NKP	PMLN5691A
	FRONT COVER KIT BT NKP	PMLN6111A
Keypad	Full Keypad, English	75012064004
	Full Keypad, Cyrillic	75012064001
	Full Keypad, Arabic	75012064002
Back Kit*	BC Kit 136-174MHz,5W,FKP,GPS,BT	PMLD4480AS
	BC Kit 136-174MHz,5W,FKP	PMLD4481AS
	BC Kit 136-174MHz,5W,LKP,GPS,BT	PMLD4483AS
	BC Kit 136-174MHz,5W,LKP	PMLD4484AS
	BC Kit 136-174MHz,5W,NKP,GPS,BT	PMLD4486AS
	BC Kit 136-174MHz,5W,NKP	PMLD4487AS
	BC Kit 403-527MHz,4W,FKP,GPS,BT	PMLE4689AS
	BC Kit 403-527MHz,4W,FKP	PMLE4690AS

Item	Description	Part Number
	BC Kit 403-527MHz,4W,LKP,GPS,BT	PMLE4692AS
	BC Kit 403-527MHz,4W,LKP	PMLE4693AS
	BC Kit 403-527MHz,4W,NKP,GPS,BT	PMLE4695AS
	BC Kit 403-527MHz,4W,NKP	PMLE4696AS
Nameplate	DP4400	33012015013
	DP4401	33012015016
	DP4600	33012015014
	DP4601	33012015017
	DP4800	33012015015
	DP4801	33012015018
Belt Clips	Belt Clip 2"	PMLN4651A
	Belt Clip 2.5"	PMLN7008A
Label	Chassis Label	54012134001

*For defective main boards, customers must order Back Kit.

5.9.4 Torque Chart

Table 5-7 lists the various screws by part number and description, followed by the torque values in different units of measure. Torque all screws to the recommended value when assembling the radio.

Table 5-7. Torque Specifications for Screws

Part Number	Description	Driver/ Socket	Torque
			lbs-in
03012034001	Screw, Main Board	T6 Torx	3.1 to 3.5
0386434Z02	Screw, Speaker Retainer	T6 Torx	2.3 to 2.5
0378212A02	Screw, Keypad Retainer	T6 Torx	1.1 to 1.3
0371160D01	Screw, Bluetooth Antenna	T3 Torx	0.4 to 0.6

Notes

Chapter 6 Basic Troubleshooting

6.1 Introduction

This chapter contains error codes and board replacement procedures. If the board does not pass all the performance checks in Chapter 3 or exhibits an error code listed below, then the circuit board should be replaced. If repair requires knowledge of details of component level troubleshooting, please send radio to a Motorola Service Center listed in Appendix A.

NOTE To access the various connector pins, use the housing eliminator/test fixture along with the diagrams found in this section of the manual. (See the section, "Service Aids" on page 2-2, for the appropriate Motorola service aids and tools parts numbers.)

6.2 Replacement Back Cover Kit Procedures

Once a problem has been isolated to a specific board, install the appropriate service kit (See Model Charts in Chapter 1), which is orderable.

If a board is replaced, it does not necessarily need to be retuned if it has been factory tuned. It should however be checked for performance before being placed into service. Of particular concern is the Bias DAC, which will need to be set for the appropriate final device bias current prior to keying up the radio. If the bias is not properly set it may be possible to cause damage to the transmitter.



Caution

The Tuner Tool only allows the serial number of the blank board to be entered once. Be very attentive during this procedure.

6.3 Power-Up Error Codes (Display Model only)

Upon powering up, the radio performs certain tests to determine if its basic electronics and software are in working order. Any error detected has an associated error code that is presented on the radio display. These error codes are intended to be used by a service technician when the radio generates the Self Test Fail Tone. If these tests are successfully completed, the radio will generate the Self Test Tone.

There are two classes of detectable errors, fatal and non-fatal. If it is considered as a fatal error, then the normal radio operation will be inhibited. Fatal errors include hardware errors detected by the microprocessor and certain memory errors. These memory errors include incorrect ROM checksum, incorrect RAM checksum, and incorrect checksums of codeplug (Persistent Storage) blocks that contain operating parameters. If the codeplug block operating parameters are corrupted, operation of the unit on the proper frequency, system, and group are in question. Attempts to use this information could provide the user with a false sense of security that others are receiving his messages. Corrupted codeplug blocks of call IDs, or their associated aliases are considered non-fatal errors. While the user may be inconvenienced, normal communication is still possible.

Table 6-1. Power-Up Error Codes

Error Code	Description	Error Type	Corrective Action
ERROR 01/02	Call ID or associated aliases codeplug block checksum is wrong.	Non-Fatal	Normal communication is still possible, but the user may be inconvenienced. Reprogram codeplug.
ERROR 01/22	Tuning Codeplug block checksum is wrong.	Non-Fatal	Normal communication is still possible.
FAIL 01/82	External Codeplug block checksum is wrong.	Fatal	Reprogram codeplug.
FAIL 01/92	Secure Codeplug checksum error	Fatal	Reprogram codeplug.
FAIL 01/A2	Tuning Codeplug block checksum is wrong.	Fatal	Reprogram codeplug.
FAIL 01/81	ROM Checksum is wrong.	Fatal	Reprogram FLASH Memory, then retest. If message reoccurs, replace main board or send radio to nearest Motorola Depot.
FAIL 01/88	Radio RAM Test Failure.	Fatal	Retest radio by turning it off and turning it on again. If message reoccurs, replace main board or send radio to nearest Motorola Depot.
FAIL 01/90 or FAIL 02/90	General hardware test failure.	Fatal	Retest radio by turning it off and turning it on again. If message reoccurs, replace main board or send radio to nearest Motorola Depot.
FAIL 02/81	DSP ROM Checksum is wrong.	Fatal	Reprogram FLASH Memory, then retest. If message reoccurs, replace main board or send radio to nearest Motorola Depot.
FAIL 02/82	DSP RAM1 test failure.	Fatal	Retest radio by turning it off and turning it on again. If message reoccurs, replace main board or send radio to nearest Motorola Depot.

Table 6-1. Power-Up Error Codes (Continued)

Error Code	Description	Error Type	Corrective Action
FAIL 02/84	DSP RAM2 test failure.	Fatal	Retest radio by turning it off and turning it on again. If message reoccurs, replace main board or send radio to nearest Motorola Depot.
FAIL 02/88	DSP RAM test failure.	Fatal	Retest radio by turning it off and turning it on again. If message reoccurs, replace main board or send radio to nearest Motorola Depot.
FAIL 02/C0	DSP ROM Checksum is wrong.	Fatal	Retest radio by turning it off and turning it on again. If message reoccurs, replace main board or send radio to nearest Motorola Depot.
No Display	Display module is not connected properly. Display module is damaged.	Fatal	Check connection between main board and display module. Replace with new display module.

NOTE A non-display radio emits only the Self Test Fail Tone if it fails the self-test

6.4 Operational Error Codes

During radio operation, the radio performs dynamic tests to determine if the radio is working properly. Problems detected during these tests are presented as error codes on the radio's display. The presence of an error code should prompt a user that a problem exists and that a Motorola Authorized MOTOTRBO dealer should be contacted. Use Table 6-2 to aid in understanding particular operational error codes.

Table 6-2. Operational Error Codes

Error Code	Description	Error Type	Corrective Action
FAIL 001	Synthesizer Out-of-Lock	NON-FATAL	1. Reprogram the codeplug. 2. Refer to Detailed Service Manual.
FAIL 002	Personality checksum or system block error	NON-FATAL	Reprogram the codeplug.

Appendix A EMEA Regional Warranty, Service and Technical Support

A.1 Warranty and Service Support

Motorola offers long term support for its products. This support includes full exchange and/or repair of the product during the warranty period, and service/ repair or spare parts support out of warranty. Any "return for exchange" or "return for repair" by an authorized Motorola Dealer must be accompanied by a Warranty Claim Form. Warranty Claim Forms are obtained by contacting an Authorized Motorola Dealer.

A.1.1 Warranty Period and Return Instructions

The terms and conditions of warranty are defined fully in the Motorola Dealer or Distributor or Reseller contract. These conditions may change from time to time and the following notes are for guidance purposes only.

In instances where the product is covered under a "return for replacement" or "return for repair" warranty, a check of the product should be performed prior to shipping the unit back to Motorola. This is to ensure that the product has been correctly programmed or has not been subjected to damage outside the terms of the warranty.

Prior to shipping any radio back to the appropriate Motorola warranty depot, please contact Customer Resources (Please see page A-3). All returns must be accompanied by a Warranty Claim Form, available from your Customer Services representative. Products should be shipped back in the original packaging, or correctly packaged to ensure no damage occurs in transit.

A.1.2 After Warranty Period

After the Warranty period, Motorola continues to support its products in two ways.

1. Motorola's Managed Technical Services (MTS) offers a repair service to both end users and dealers at competitive prices.
2. MTS supplies individual parts and modules that can be purchased by dealers who are technically capable of performing fault analysis and repair.

A.2 European Radio Support Centre (ERSC)

The ERSC Customer Information Desk is available through the following service numbers:

Austria:	08 00 29 75 41	Italy:	80 08 77 387
Belgium:	08 00 72 471	Luxemburg:	08 00 23 27
Denmark:	80 88 58 80	Netherlands:	08 00 22 45 13
Finland:	08 00 11 49 910	Norway:	80 01 11 15
France:	08 00 90 30 90	Portugal:	08 00 84 95 70
Germany:	08 00 18 75 240	Spain:	90 09 84 902
Greece:	00 80 04 91 29 020	Sweden:	02 07 94 307
UK :	08 00 96 90 95	Switzerland:	08 00 55 30 82
Ireland:	18 00 55 50 21	Iceland:	80 08 147

Or dial the European Repair and Service Centre:

Telephone: +49 30 6686 1555

Fax ERSC: +49 30 6686 1579

Email ERSC: ERSC@motorolasolutions.com

Please use these numbers for repair enquiries only.

A.3 Piece Parts

Some replacement parts, spare parts, and/or product information can be ordered directly.

If a complete Motorola part number is assigned to the part, it is available from Motorola Radio Products and Solutions Organization (RPSO). If no part number is assigned, the part is not normally available from Motorola. If the part number is appended with an asterisk, the part is serviceable by Motorola Depot only. If a parts list is not included, this generally means that no user-serviceable parts are available for that kit or assembly.

Orders for replacement parts, kits and assemblies should be placed directly on Motorola's local distribution/dealer organisation or via Motorola Online at: <http://www.motorola.com/emeaonline>

* The Radio Products and Solutions Organization (RPSO) was formerly known as the Radio Products Services Division (RPSD) and/or the Accessories and Aftermarket Division (AAD).

A.4 Technical Support

Motorola Product Services is available to assist the dealer/distributors in resolving any malfunctions which may be encountered.

North Europe – Stephen Woodrow
Telephone: +44 (0) 1256 488 082
Fax: +44 01256 488 080
Email: CSW066@motorolasolutions.com

Central and East Europe – Siggý Punzenberger
Telephone: +49 (0) 6128 70 2342
Fax: +49 (0) 6128 95 1096
Email: TFG003@motorolasolutions.com

Russia and Armenia – Andrey Nagornykh
Telephone: +7 495 787 8910
Fax: +7 495 785 0185
Email: mwcb47@motorolasolutions.com

Germany – Customer Connect Team
Telephone: +49 (0) 30 6686 1539
Fax: +49 (0) 30 6686 1916
Email: ESSC@motorolasolutions.com

Middle East and Africa – Wayne Holmes
Telephone: +49 (0) 6126 957 6237
Fax: +49 (0) 6126 957 6826
Email: wayne.holmes@motorolasolutions.com

Italy – Ugo Gentile
Telephone: +39 02 5220 7825
Fax: +39 02 5220 7810
Email: Ugo.Gentile@motorolasolutions.com

France – Armand Roy
Telephone: +33 1 6935 7868
Fax: +33 1 6935 7808
Email: armand.roy@motorolasolutions.com

France – Laurent Irrmann
Telephone: +33 1 6935 7866
Fax: +33 1 6935 7808
Email: laurent.irrmann@motorolasolutions.com

A.5 Further Assistance From Motorola

You can also contact the Customer Help Desk through the following web address.
<http://www.motorolasolutions.com/governmentandenterprise>

Notes

Appendix B Limited Level 3 Servicing

B.1 Maintenance

For details on the following, please refer to [“Chapter 5 Disassembly/Reassembly Procedures” on page 5-1 to section 5.4 on page 5-4.](#)

Section 5.2 on page 5-1 to Section 5.4 on page 5-4.

- Preventive maintenance (inspection and cleaning).
- Safe handling of CMOS and LDMOS devices.
- Repair procedures and techniques.

B.2 Chip Components

Use a Hot-Air Repair Station for chip component replacement. Adjust the temperature control to 370°C (700°F), and adjust the airflow to a minimum setting. Airflow can vary due to component density.

- **To remove a chip component:**

1. Use a hot-air hand piece and position the nozzle of the hand piece approximately 0.3 cm (1/8") above the component to be removed.
2. Begin applying the hot air. Once the solder reflows, remove the component using a pair of tweezers.
3. Using a solder wick and a soldering iron or a power desoldering station, remove the excess solder from the pads.

- **To replace a chip component using a soldering iron:**

1. Select the appropriate micro-tipped soldering iron and apply fresh solder to one of the solder pads.
2. Using a pair of tweezers, position the new chip component in place while heating the fresh solder.
3. Once solder wicks onto the new component, remove the heat from the solder.
4. Heat the remaining pad with the soldering iron and apply solder until it wicks to the component. If necessary, touch up the first side. All solder joints should be smooth and shiny.

- **To replace a chip component using hot air:**

1. Use the hot-air hand piece and reflow the solder on the solder pads to smooth it.
2. Apply a drop of solder paste flux to each pad.
3. Using a pair of tweezers, position the new component in place.
4. Position the hot-air hand piece approximately 0.3 cm (1/8") above the component and begin applying heat.
5. Once the solder wicks to the component, remove the heat and inspect the repair. All joints should be smooth and shiny.

B.3 Component and Parts list

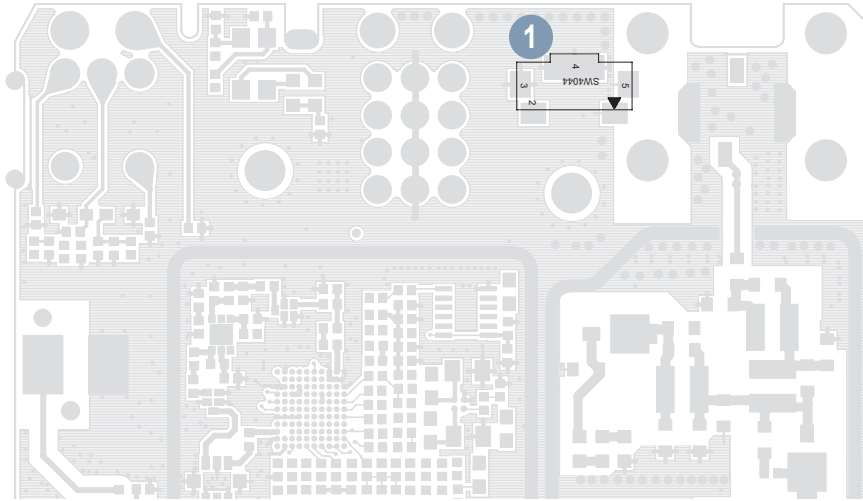

Figure B-1. PCB Top View

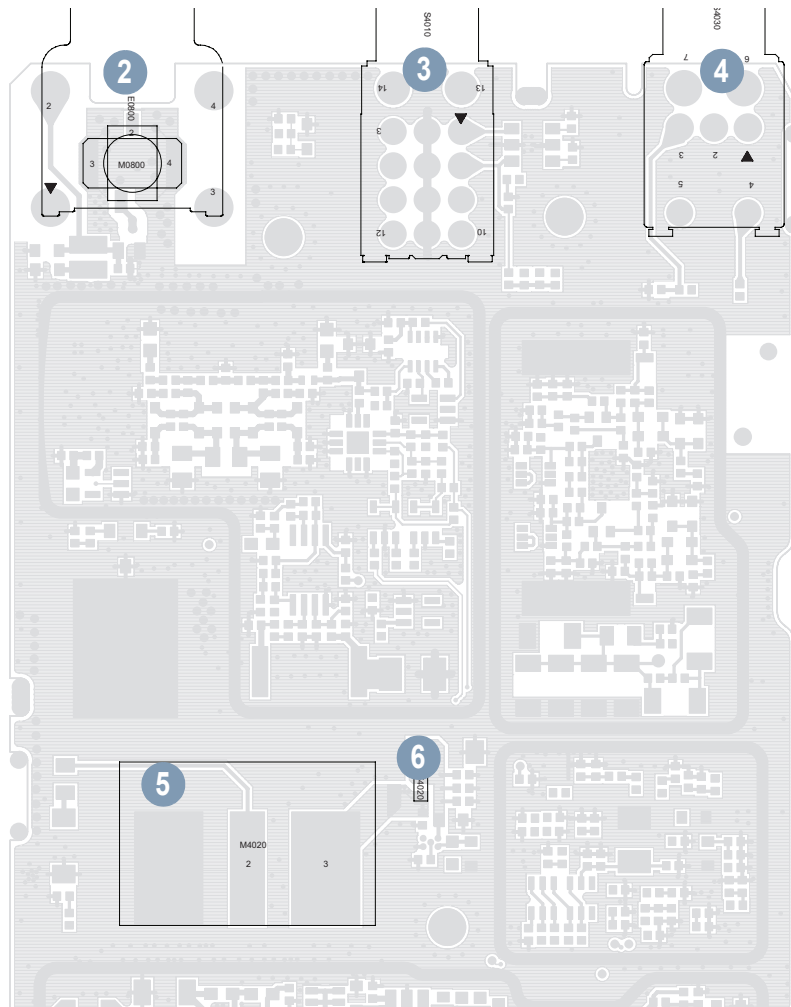

Figure B-2. PCB Bottom View

Table B-1 Component Parts List

No.	Circuit Ref	Motorola Part Num.	Description
1	SW4044	4086470Z01	SPST Tact Switch
2	M0800 E0800	0987378K01 02012010001	SM Coaxial Connector Female
3	S4010	40012023001	Frequency Switch
4	S4030	1875103C04	Volume Rotary On/Off Switch
5	M4020	0915184H01	Battery Contact Connector
6	F4020	6515076H01	Fuse Fast Blow 3A 24V

Notes

Glossary

This glossary contains an alphabetical listing of terms and their definitions that are applicable to portable and mobile subscriber radio products. All terms do not necessarily apply to all radios, and some terms are merely generic in nature.

Term	Definition
Analog	Refers to a continuously variable signal or a circuit or device designed to handle such signals.
Band	Frequencies allowed for a specific purpose.
CPS	Customer Programming Software: Software with a graphical user interface containing the feature set of a radio.
Default	A pre-defined set of parameters.
DP	Refers to Digital Professional Radio model names in the MOTOTRBO Professional Digital Two-Way Radio System.
Digital	Refers to data that is stored or transmitted as a sequence of discrete symbols from a finite set; most commonly this means binary data represented using electronic or electromagnetic signals.
DPL	Digital Private-Line: A type of digital communications that utilizes privacy call, as well as memory channel and busy channel lock out to enhance communication efficiency.
FCC	Federal Communications Commission.
Frequency	Number of times a complete electromagnetic-wave cycle occurs in a fixed unit of time (usually one second).
GPIO	General-Purpose Input/Output: Pins whose function is programmable.
GPS	Global Positioning System.
IC	Integrated Circuit: An assembly of interconnected components on a small semiconductor chip, usually made of silicon. One chip can contain millions of microscopic components and perform many functions.
IF	Intermediate Frequency.
kHz	kilohertz: One thousand cycles per second. Used especially as a radio-frequency unit.
LCD	Liquid-Crystal Display: An LCD uses two sheets of polarizing material with a liquid-crystal solution between them. An electric current passed through the liquid causes the crystals to align so that light cannot pass through them.
LED	Light Emitting Diode: An electronic device that lights up when electricity is passed through it.

Term	Definition
MDC	Motorola Digital Communications.
MHz	Megahertz: One million cycles per second. Used especially as a radio-frequency unit.
Paging	One-way communication that alerts the receiver to retrieve a message.
PC Board	Printed Circuit Board. Also referred to as a PCB.
PL	Private-Line Tone Squelch: A continuous sub-audible tone that is transmitted along with the carrier.
Programming Cable	A cable that allows the CPS to communicate directly with the radio using USB.
Receiver	Electronic device that amplifies RF signals. A receiver separates the audio signal from the RF carrier, amplifies it, and converts it back to the original sound waves.
Repeater	Remote transmit/receive facility that re-transmits received signals in order to improve communications range and coverage (conventional operation).
RF	Radio Frequency: The portion of the electromagnetic spectrum between audio sound and infrared light (approximately 10 kHz to 10 GHz).
RX	Receive.
Signal	An electrically transmitted electromagnetic wave.
Spectrum	Frequency range within which radiation has specific characteristics.
Squelch	Muting of audio circuits when received signal levels fall below a pre-determined value. With carrier squelch, all channel activity that exceeds the radio's preset squelch level can be heard.
TOT	Time-out Timer: A timer that limits the length of a transmission.
TPL	Tone Private Line.
Transceiver	Transmitter-receiver. A device that both transmits and receives analog or digital signals. Also abbreviated as XCVR.
Transmitter	Electronic equipment that generates and amplifies an RF carrier signal, modulates the signal, and then radiates it into space.
TX	Transmit.
UHF	Ultra-High Frequency.
USB	Universal Serial Bus: An external bus standard that supports data transfer rates of 12 Mbps.
VIP	Vehicle Interface Port.

Notes

